

ATORNILLADORES ELÉCTRICOS

delvo

GENERAL CATALOG



Nitto Kohki's "delvo" contributes to improvement of assembly quality.



"delvo", a screwdriver that realizes high precision torque management

Products with high reliability are born only with reliable tools.

High Precision

A high precision torque is a must to improve assembly quality. "delvo" has high repeatable torque accuracy, and it is possible to equalize the tightening torque.

Long Life

"delvo" with brush motor uses a long life motor that withstands a guaranteed fastening cycle of a million times. "delvo" with brushless motor are eco-friendly and maintenance free that realize high durability.

Shockless

Original clutch and motor stop mechanism minimizes the shock at the end of the screw fastening. It reduces the fatigue of screw fastening.



NITTO KOHKI has made every effort in environmental improvement schemes on a company-wide basis through the implementation of ISO14001 to execute environmentally conscious business activities. As a part of our ongoing commitment to improve the environment, we are also committed to exclude or reduce restricted chemical substances in our products, as designated by the RoHS directives and Laws and Regulations of Chemical Substances in Japan. For further details, please see the following:

Nitto Kohki group companies' Green Procurement Guidelines have been established by their environmental committee which consists of members from all the Nitto Kohki group of companies. Nitto Kohki group companies give preferential treatment to suppliers that work to an environmental policy framework. Nitto Kohki group companies periodically survey their suppliers to ensure their chemical management systems include the monitoring of environmental issues such as the RoHS directives, and Japanese laws and regulations of Chemical Substances to minimize packaging and waste. We are continuing our goal to ensure that our made-to-order items are also covered by our environmental policy.

Green Procurement Policy

Each of the Nitto Kohki group companies is clarifying the control categories of the environmental management substances included in the parts and auxiliary materials constituting Nitto Kohki products and those of the environmental management substances used in the manufacturing processes. We will promote prohibition and reduction of use of the environmental management substances according to such control categories. Through these activities, we will comply with various laws and regulations related to the environmental management substances and reduce the impact to the global environmental conservation and to the ecological system.

Scope of Application

Our Green Procurement Guideline applies to all materials, parts, products, and auxiliary materials which Nitto Kohki Group companies purchase for production or sales.

Our Green Procurement Activities

NITTO KOHKI group companies continually aim to comply with RoHS directives, and Japanese laws and regulations of Chemical Substances.

- Standard products have been RoHS compliant. Green procurement activities on made-to-order products are continuing.
- NITTO KOHKI group companies are now working to the REACH Regulation.
- NITTO KOHKI group companies are building a database of the chemical management substances regulated by the RoHS directives, the REACH Regulation and Japanese laws and regulations of Chemical Substances.

Classification in this catalog



Power type	— The type of power source is indicated.
Brush motor Brushless motor	— The type of motor is indicated.
Miniature screw Precision screw Machine screw	— The type of screw* is indicated.
Screw Size	— The size range of screw is indicated.

* Miniature screw ... for 1.0 to 2.6 mm
 Precision screw ... for 1.0 to 3.5 mm
 Machine screw ... for 2.6 to 8.0 mm

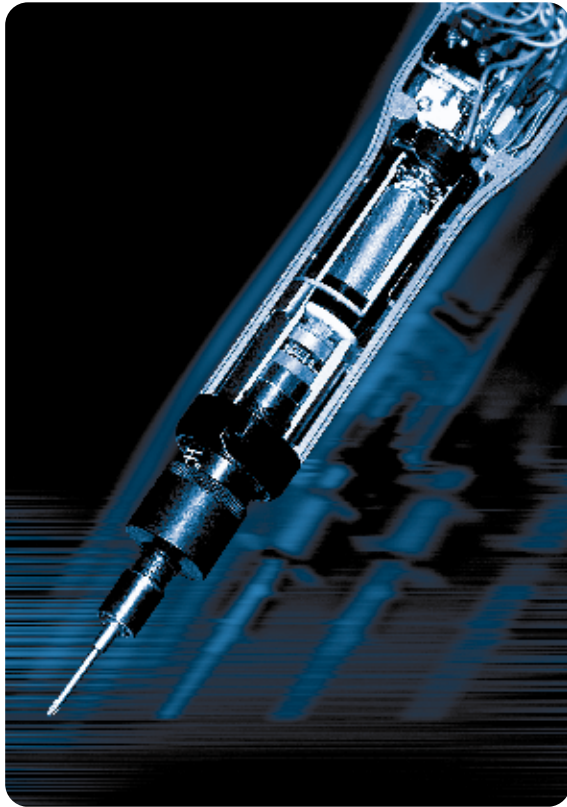













About Torque Management

The fastening torque generated on the screw varies depending on the screw size, material and the type of workpiece. Always check and manage the torque generated on the screw with a torque wrench., etc. The fastening torque varies depending on the fastening conditions.



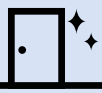





CONTENTS

List of Screwdrivers	3
C Series (Current Control Type)	7
S Series (Variable Speed Type)	10
A Series (Low Voltage Type [DC])	13
A Series (Transformerless Type [AC])	14
DLV02/12/16 Series	15
DLV7400A Series	16
DLV5700 Series	17
DLV5800 Series	18
DLV7300 Series	19
DLV7300-BME/BKE Series	20
DLV7500/8500 Series	21
DLV7000/8000 Series	24
DLV7100/7200/8100/8200 Series	25
DLV7104/8104/8204 Series	26
Screw Fastening Counters	27
DLR5640-WN	29
Screwdrivers designed for DLR5640-WN	30
DLR5040A/5340-WE	31
Screwdrivers designed for DLR5040A/5340-WE	32
A Series (For Automation)	33
DLV3100/3300 Series (For Automation)	35
DLT1173A/1673A/1973A	36
NK BIT	37
Vacuum Pickups and Sleeves	39
Accessories	40
Safety guide	42

Quick Reference Symbols

 Lever Start Operates when the lever is pressed.	 Push to Start Operates when the screwdriver is pressed.	 Transformerless A dedicated controller is not required. Operates by commercial power supply.	 Low Low Voltage Connect to dedicated controller. Operates at electric voltage under 42V.
 Brushless Motor Maintenance free, no brush replacement required. Realizes high durability.	 Grounded Bit Prevents electrostatic breakdown when the bit contacts the workpiece.	 ESD Protection Prevents electrostatic charging and saves the workpiece from electrostatic breakdown.	 Low Shock Softens the shock at the end of tightening and lowers the load to the workpiece.
 Clean room adaption Adapts to assembly in class 5 clean rooms	 Soft Soft Stop Gradually reduces the rotation speed to improve the screw tightening quality.	 Variable Speed Can be adjusted to a suitable tightening speed.	 Soft Soft Start Gradually increases the rotation speed to prevent damage to the screw head.













[Brushless Motor - DC Power Supply]

Page	Outer Appearance	Series	Model	Torque Range (Nm [lbf·in])	Screw Size (mm)		Mass (g [lbs])	Lever Start	Push to Start	ESD Protection	Soft Stop	Low Speed	Medium Speed	High Speed	Built-in Screw Counter	SPC Type available (for screw counter)	Controller	
					min.	max.											Model	Outer Appearance
7		C Series (Current control type)	DLV04C10L	0.05 - 0.4 [0.4 - 3.5]	1.2	3.0	370 [0.82]	●		●		●	●			DCC0101		
			DLV10C10L	0.2 - 1.0 [1.8 - 8.9]	1.8	4.0		●		●		●	●					
10		S Series (Variable speed type)	DLV30S06L	0.4 - 3.0 [3.5 - 26.6]	2.6	5.0	710 [1.57]	●	●	●	●				●	DEA0151N-AZ or DEA0241N-AZ		
			DLV30S06P					●	●	●	●				●			
			DLV30S12L					●	●	●	●				●			
			DLV30S12P					●	●	●	●				●			
			DLV30S20L	●							●	DEA0241N-AZ						
			DLV30S20P	●						●								
			DLV45S06L	2.0 - 4.5 [17.7 - 39.8]	4.5	6.0	860 [1.90]	●	●	●	●				●	DEA0151N-AZ or DEA0241N-AZ		
			DLV45S06P					●	●	●	●				●			
			DLV45S12L					●	●	●	●				●			
			DLV45S12P	●							●	DEA0241N-AZ						
DLV70S06L	3.8 - 7.0 [33.6 - 62.0]	5.0	8.0	●	●	●	●				●							
DLV70S06P	●							●			●							
13		A Series	DLV30A06L	0.4 - 3.0 [3.5 - 26.6]	2.6	5.0	690 [1.52]	●	●	●	●					DEA0151N-AZ or DEA0241N-AZ		
			DLV30A06P					●	●	●	●				●			
			DLV30A12L					●	●	●	●				●			
			DLV30A12P					●	●	●	●				●			
			DLV30A20L	●							●	DEA0241N-AZ						
			DLV30A20P	●						●								
			DLV45A06L	2.0 - 4.5 [17.7 - 39.8]	4.5	6.0	840 [1.85]	●	●	●	●				●	DEA0151N-AZ or DEA0241N-AZ		
			DLV45A06P					●	●	●	●				●			
			DLV45A12L					●	●	●	●				●			
			DLV45A12P	●							●	DEA0241N-AZ						
DLV70A06L	3.8 - 7.0 [33.6 - 62.0]	5.0	8.0	●	●	●	●				●							
DLV70A06P	●							●			●							
15		DLV02/12/16	DLV02SL-CKE	0.03 - 0.2 [0.3 - 1.8]	1.0	2.2	470 [1.04]	●		●	●	●				DLC16S		
			DLV02SL-BKE	●		●		●			●	●						
			DLV12SL-CKE	0.15 - 1.2 [1.3 - 10.6]	1.4	3.0		●		●	●							
			DLV12SL-BKE	●		●		●			●	●						
			DLV16SL-CKE	0.2 - 1.6 [1.8 - 14.2]	2.2	4.0		●		●	●							
			DLV16SL-BKE	●		●		●			●	●						



[Brushless Motor - AC Power Supply]

Page	Outer Appearance	Series	Model	Torque Range (Nm [lbf·in])	Screw Size (mm)		Mass (g [lbs])	Lever Start	Push to Start	ESD Protection	Soft Stop	Low Speed	Medium Speed	High Speed	Built-in Screw Counter	SPC Type available (for screw counter)
					min.	max.										
14		A Series	DLV30A06L	0.4 - 3.0 [3.5 - 26.6]	2.6	5.0	700 [1.54]	●				●				●
			DLV30A06P					●				●			●	
			DLV30A12L					●				●			●	
			DLV30A12P					●				●			●	
			DLV30A20L	●							●	DEA0241N-AZ				
			DLV30A20P	●						●						
			DLV45A06L	2.0 - 4.5 [17.7 - 39.8]	4.5	6.0	870 [1.92]	●	●	●	●				●	DEA0151N-AZ or DEA0241N-AZ
			DLV45A06P					●	●	●	●				●	
			DLV45A12L					●	●	●	●				●	
			DLV45A12P	●							●	DEA0241N-AZ				
DLV70A06L	3.8 - 7.0 [33.6 - 62.0]	5.0	8.0	●	●	●	●				●					
DLV70A06P	●							●			●					

[Brush Motor - DC Power Supply]

Page	Outer Appearance	Series	Model	Torque Range (Nm [lbf·in])	Screw Size (mm)		Mass (g [lbs])	Lever Start	Push to Start	ESD Protection	Clean Room Type	High Speed	Low Shock	SPC Type available (for screw counter)	Controller		
					min.	max.									Model	Adjustable speed	Outer Appearance
16		7400A	DLV7410A	0.02 - 0.2 [0.2 - 1.8]	1.0	2.3	230 [0.51]	●	●	●	●	●	●	DLC1110	●		
			DLV7410HA														
			DLV7420A	0.15 - 0.4 [1.3 - 3.5]	1.6	2.6	●	●	●	●	●						
			DLV7419A	0.02 - 0.2 [0.2 - 1.8]	1.0	2.3	275 [0.61]	●	●	●	●	●					
			DLV7419HA														
DLV7429A	0.15 - 0.4 [1.3 - 3.5]	1.6	2.6	●	●	●	●	●									
17		5700	DLV5720	0.02 - 0.2 [0.2 - 1.8]	1.0	2.3	230 [0.51]	●	●	●	●	●		DLC0350	●		
			DLV5720H														
			DLV5740	0.15 - 0.4 [1.3 - 3.5]	1.6	2.6	●	●	●	●	●						
			DLV5740H														
18		5800	DLV5820	0.02 - 0.2 [0.2 - 1.8]	1.0	2.3	230 [0.51]	●	●	●	●	●		DLC0250E	●		
			DLV5820H														
			DLV5840	0.15 - 0.4 [1.3 - 3.5]	1.6	2.6	●	●	●	●	●						
21		7300	DLV7313	0.03 - 0.15 [0.3 - 1.3]	Up to 2.0		350 [0.77]	●						DLC1213A	●		
			DLV7323	0.05 - 0.5 [0.4 - 4.4]	1.0	3.0		●									
			DLV7333	0.3 - 1.2 [2.7 - 10.6]	2.0	3.5	●										
			DLV7325	0.05 - 0.5 [0.4 - 4.4]	1.0	3.0	400 [0.88]	●	●	●	●	●					
			DLV7335	0.3 - 1.2 [2.7 - 10.6]	2.0	3.5		●	●	●	●	●					
20		7300-BME/ BKE	DLV7321	0.05 - 0.5 [0.4 - 4.4]	1.0	3.0	350 [0.77]	●	●	●	●	●		DLC1213A	●		
			DLV7331	0.3 - 1.2 [2.7 - 10.6]		3.5		●	●	●	●	●					
			DLV7319	0.2 - 0.4 [1.8 - 3.5]	2.0	3.0	●	●	●	●	●						
			DLV7329	0.25 - 0.55 [2.2 - 4.9]		3.0	400 [0.88]	●	●	●	●	●					
			DLV7339	0.45 - 0.95 [4.0 - 8.4]		3.5		●	●	●	●	●					
			DLV7349	0.55 - 1.2 [4.9 - 10.6]	3.0	3.5	●	●	●	●	●						
21		7500	DLV7530-MKE	0.5 - 1.7 [4.4 - 15.1]	2.6	4.0	650 [1.43]	●		●				DLC4511	●		
			DLV7530-BKE														
			DLV7540-MKE	1.2 - 2.7 [10.6 - 23.9]	3.5	5.0	●		●								
			DLV7540-BKE				●		●								
			DLV7550-MKE	2.0 - 4.5 [17.7 - 39.8]	4.5	6.0	750 [1.65]	●		●							
	DLV7550-BKE				●			●									
		8500	DLV8530-MKE	0.5 - 1.7 [4.4 - 15.1]	2.6	4.0	650 [1.43]	●	●	●	●	●					
			DLV8530-BKE														
			DLV8540-MKE	1.2 - 2.7 [10.6 - 23.9]	3.5	5.0	●		●								
			DLV8540-BKE				●		●								
DLV8550-MKE			2.0 - 4.5 [17.7 - 39.8]	4.5	6.0	750 [1.65]	●		●								
DLV8550-BKE				●			●										

[Brush Motor - AC Power Supply]

Page	Outer Appearance	Series	Model	Torque Range (Nm [lbf·in])	Screw Size (mm)		Mass (g [lbs])	Lever Start	Push to Start	ESD Protection	High Speed	SPC Type available (for screw counter)		
					min.	max.								
24		7000	DLV7020	0.05 - 0.55 [0.4 - 4.9]	1.0	3.0	400 [0.88]	●				●		
			DLV7030	0.3 - 1.1 [2.7 - 9.7]	2.0	3.5		●				●		
			DLV7031	0.3 - 1.0 [2.7 - 8.9]					●		●	●		
		8000	DLV8020	0.1 - 0.55 [0.9 - 4.9]	1.0	3.0	410 [0.90]		●				●	
			DLV8030	0.3 - 1.1 [2.7 - 9.7]	2.0	3.5		●				●		
			DLV8031	0.3 - 1.0 [2.7 - 0.9]					●		●	●		
25		7100/ 7200	DLV7120	0.35 - 0.70 [3.1 - 6.2]	2.6	3.0	700 [1.54]	●					●	
			DLV7130	0.5 - 1.7 [4.4 - 15.1]		4.0		●				●		
			DLV7140	1.2 - 3.0 [10.6 - 26.6]	3.5	5.0		●				●		
			DLV7221	0.35 - 0.7 [3.1 - 6.2]	2.6	3.0		●			●			
			DLV7231	0.5 - 1.7 [4.4 - 15.1]		4.0		●			●	●		
			DLV7241	1.2 - 3.0 [10.6 - 26.6]	3.5	5.0		●				●		
			DLV7251	2.0 - 4.5 [17.7 - 39.8]	4.5	6.0		890 [1.96]	●				●	
		8100/ 8200	DLV8120	0.35 - 0.70 [3.1 - 6.2]	2.6	3.0	690 [1.52]		●					●
			DLV8130	0.5 - 1.7 [4.4 - 15.1]		4.0		●				●		
			DLV8140	1.2 - 3.0 [10.6 - 26.6]	3.5	5.0		●				●		
			DLV8150	2.0 - 4.5 [17.7 - 39.8]	4.5	6.0		890 [1.96]	●				●	
			DLV8221	0.35 - 0.7 [3.1 - 6.2]	2.6	3.0		●			●			
			DLV8231	0.5 - 1.7 [4.4 - 15.1]		4.0		690 [1.52]	●			●	●	
			DLV8241	1.2 - 3.0 [10.6 - 26.6]	3.5	5.0		●				●		
DLV8251	2.0 - 4.5 [17.7 - 39.8]	4.5	6.0	890 [1.96]	●				●					
26		7104/ 8104/ 8204	DLV7124	0.25 - 0.75 [2.2 - 6.6]	2.6	3.0	720 [1.59]	●		●				
			DLV7134	0.5 - 1.7 [4.4 - 15.1]		4.0		●			●			
			DLV7144	1.2 - 3.0 [10.6 - 26.6]	3.5	5.0		●			●			
			DLV8124	0.25 - 0.75 [2.2 - 6.6]	2.6	3.0	710 [1.57]		●		●			
			DLV8134	0.5 - 1.7 [4.4 - 15.1]		4.0		●			●			
			DLV8144	1.2 - 3.0 [10.6 - 26.6]	3.5	5.0		●			●			
			DLV8154	2.0 - 4.5 [17.7 - 39.8]	4.5	6.0	910 [2.01]	●			●			
			DLV8224	0.35 - 0.7 [3.1 - 6.2]	2.6	3.0	710 [1.57]		●		●	●		
			DLV8234	0.5 - 1.7 [4.4 - 15.1]		4.0		●			●	●		
			DLV8244	1.2 - 3.0 [10.6 - 26.6]	3.5	5.0		●			●			

[Brushless Motor]

Page	Outer Appearance	Series	Model	Torque Range (Nm [lbf·in])	Screw Size (mm)		Mass (g [lbs])	Low Speed	Medium Speed	High Speed	Coupling			
					min.	max.					Standard	Flange	M41 Screw	
33		A Series (for automation)	DLV30A06A-N	0.4 - 3.0 [3.5 - 26.6]	2.6	5.0	700 [1.54]	●			●			
			DLV30A06A-F				760 [1.68]	●			●			
			DLV30A06A-M				740 [1.63]	●				●		
			DLV30A12A-N				700 [1.54]		●		●			
			DLV30A12A-F				760 [1.68]		●		●			
			DLV30A12A-M				740 [1.63]		●			●		
			DLV30A20A-N				700 [1.54]			●		●		
			DLV30A20A-F				760 [1.68]			●		●		
			DLV30A20A-M				740 [1.63]			●			●	
			DLV45A06A-N	2.0 - 4.5 [17.7 - 39.8]	4.5	6.0	780 [1.72]	●				●		
			DLV45A06A-F				840 [1.85]	●				●		
			DLV45A06A-M				820 [1.81]	●					●	
			DLV45A12A-N				780 [1.72]		●			●		
			DLV45A12A-F				840 [1.85]		●			●		
			DLV45A12A-M				820 [1.81]		●				●	
			DLV70A06A-N	3.8 - 7.0 [33.6 - 62.0]	5.0	8.0	780 [1.72]	●				●		
			DLV70A06A-F				840 [1.85]	●				●		
			DLV70A06A-M				820 [1.81]	●					●	



Standard coupling



Flange coupling



M41 screw coupling

[Brush Motor]

Page	Outer Appearance	Series	Model	Torque Range (Nm [lbf·in])	Screw Size (mm)		Mass (g [lbs])	Controller	
					min.	max.		Model	
35		3100 (for automation)	DLV3121	0.25 - 0.7 [2.2 - 6.2]	2.3	2.6	900 [1.98]	Transformerless (controller not required)	
			DLV3131	0.5 - 1.5 [4.4 - 13.3]	2.6	3.5			
			DLV3141	1.2 - 3.0 [10.6 - 26.6]	3.5	5.0			
			DLV3151	2.0 - 4.5 [17.7 - 39.8]	4.5	6.0			
		3300 (for automation)	DLV3321	0.05 - 0.5 [0.4 - 4.4]	1.0	3.0	400 [0.88]	DLC3310	
			DLV3331	0.3 - 1.2 [2.7 - 10.6]	2.0	3.5			

Low Voltage (DC)
 Brush motor **Brushless motor**
 Miniature screw Precision screw Machine screw
 1.2 - 4.0 mm



delvo Brushless Type

C Series (Current control Type) Model DLV04C/10C CE



Features

- Easy fastening setting by controller
- Current Controlled Torque System suitable for screw fastening work
- Low-voltage brushless motor
- ESD (electrostatic discharge) protection structure
- For both hand-held / automatic machines
- Controller has built in counting function. Prevents human errors

Four screwdrivers can be consolidated into one

- **Controller can be set to any torque and speed within range.**

* The range varies depending on SOFT fastening or HARD fastening.

0.25 Nm	450 min ⁻¹		1st unit
0.15 Nm	600 min ⁻¹		2nd unit
0.35 Nm	1000 min ⁻¹		3rd unit
0.30 Nm	450 min ⁻¹		4th unit



Torque: **0.05 - 0.4 Nm** (DLV04C)
 [0.44 - 3.54 lbf·in]
0.2 - 1.0 Nm (DLV10C)
 [1.77 - 8.85 lbf·in]
 Speed: **100 - 1000 min⁻¹**

Torque range **0.05 - 1.0 Nm**



* When the same bit is used.

All in one!

- **Easily adapts for use in automatic machines**

The sequencing of the screwdrivers can be controlled by a PLC.



DLP6650

For installation on automatic assembly machines, attach optional flange coupling (DLW9015) or vacuum pickup (DLP6650).



- **Built-in Screw Fastening Counter Function**

Controller has built in counting function. Prevents human errors.

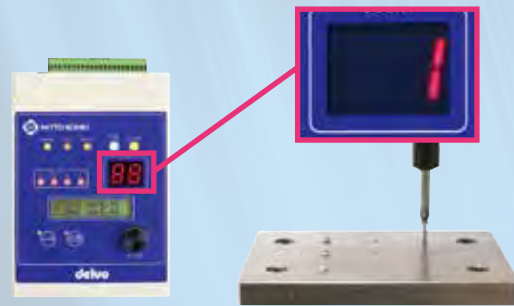

Specifications

Model	Bit	CE/UL	DLV04C10L-AY	K	DLV10C10L-AY	K
		PSE	DLV04C10L-AZ	M	DLV10C10L-AZ	M
Power Source		DCC0101X-AZP or DCC0101X-AZN				
Torque Adjustment		Stepless				
Torque	SOFT fastening setting (1000 min ⁻¹ setting)	0.05 - 0.4 [0.4 - 3.5]		0.2 - 1.0 [1.8 - 8.9]		
	SOFT fastening setting (600 min ⁻¹ setting)	0.05 - 0.35 [0.4 - 3.1]		0.2 - 0.45 [1.8 - 4.0]		
	HARD fastening setting	0.05 - 0.4 [0.4 - 3.5]		0.2 - 1.0 [1.8 - 8.9]		
Free Speed (min ⁻¹)	SOFT fastening setting	600 - 1000				
	HARD fastening setting	100 - 1000				
Screw Size (mm)	Machine screw	1.2 - 3.0		1.8 - 4.0		
	Tapping screw	1.1 - 2.5		1.6 - 3.5		
Bit Type		NK35 (OD6.35 mm [1/4"] Hex. Shank)				
Input Voltage		24 V DC				
Mass		370 g [0.82 lbs]				
Rated Operation		ON: 0.5 seconds / OFF: 3.5 seconds				





Please contact us for 4 mm bit type ("M" Bit) of CE/UL models.

Model	DCC0101X-AZ : P*
Input Voltage	AC100 - 240 V AC, 50/60Hz
Operation Channel Function	Torque and speed setting in 4-channel memory Can switch to any operation channel
Count Function	Tracks screws fastened Workpiece detector can be incorporated
External Start up Control Function	Start up control can be enabled by external input signal
Input Signal Method	Photocoupler input (24 V DC drive (5 mA/1 input), respond to PNP output)
Output Signal Method	Photocoupler output (30 V DC or less, 30 mA/1 output or less, PNP output method)
Service Power Source	24 V DC (Maximum capacity 200 mA)
Power consumption	When on standby: 20 W During electric screwdriver rotation (rated): 30 W
Mass	1100 g [2.4 lbs]
Power cord (Optional)*	DLW9220 / DLW9240 / DLW9250

*DCC0101X-AZN with NPN output also available

*The power cord is sold separately. Ask us for the required power cord when ordering. (see page 9 "Optional Accessories")

Comparison of Adjustment Method with Conventional Model

Torque adjustment	 <p>Torque is adjusted by turning the adjustment ring at the end of the screwdriver.</p>	 <p>Can be set with the external controller. No need to adjust the screwdriver body.</p>
	Conventional	C Series
Speed setting	 <p>The speed of transformerless type screwdrivers is fixed for each series.</p>	 <p>Can be set with the external controller. Adjustable between 100 to 1000 min⁻¹.</p>

SOFT / HARD Fastening Settings

Two types of fastening mode available subject to the workpiece.

Coordinate the actual workpieces, screws and operating conditions and determine the fastening mode.

SOFT fastening setting Suitable for workpieces with high fastening load such as tapping screws or fastening soft objects such as rubber.

HARD fastening setting Suitable for workpieces with small fastening load such as threaded holes or rigid bodies such as metal.

Output Torque and Rotation Speed

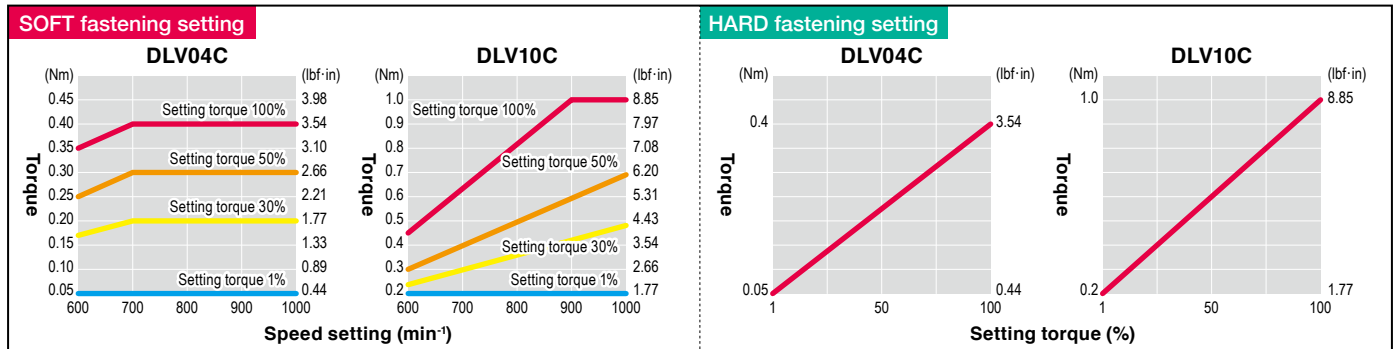

*The graph is for guidance only. The output torque range is not guaranteed.

External Signals

You can input or output external signals via a signal terminal block.

Terminal No.	Function	Details	I/O
1 (+)	+24 V DC	Built-in service power source (Capacity: Maximum 200 mA) • Use in power source for input/output signal common wire, or for the workpiece detection sensor, etc.	Service power source
2 (-)	0 V DC		
3	Channel A	In the 2-bit input signal, specify the operation channel (CH1 to CH4) • Valid only when "operation channel switching method" (No.1 CH-CHG) is set to "INPUT"	Input
4	Channel B		
5	Forward rotation startup	Startup with external input signal	
6	Reverse rotation startup		
7	WORK	Input the workpiece signal (workpiece detection sensor output) • With "count function" (No.11 COUNT-FNC) and "workpiece signal" (No.12 WORK-SNSR) set to ON, the workpiece signal input is valid	Input
8	WORK RESET	Reset operation (same as controller [WORK RESET] button)	
9	Keylock	Lock the controller button operation • Disable the controller button operation, and prevent setting changes by the operator	Output
10	Input signal negative common wire	Connect 0 V DC* • Service power source (terminal No.2) or external 0 V DC power source can be connected	
11	Forward rotation signal	Set output signal during forward rotation to ON	
12	Reverse rotation signal	Set output signal during reverse rotation to ON	
13	Count-up (C-UP)	Performance of normal screw tightening (torque-up) sets output signal to 0.3 seconds ON	
14	Screw fastening NG (F-NG)	If screw fastening NG, sets output signal to 0.3 seconds ON	
15	Operation channel 1 (CH1)	Set the channel output signal to ON during operation or settings	
16	Operation channel 2 (CH2)		
17	Operation channel 3 (CH3)		
18	Operation channel 4 (CH4)		
19	Operation OK	If the set count screw tightening is judged to be completed and operation OK, the output signal is set to ON	
20	Operation NG	When the WORK input signal is OFF during an operation, and the operation is judged to be NG, the output signal is ON	
21	Space	Connection impossible	
22	Output signal positive common wire	Connect +24 V DC* • Service power source (terminal No.1) or external +24 V DC can be connected	

*When PNP output

Delvo Brushless Type

Optional Accessories

Grounded 3-Prong Power Cord

DLW9220



North America

DLW9240



Europe

DLW9250



UK

Screw vacuum pump

DLP2530 (100 V), DLP2570 (230 V)

Connect the tube to the vacuum pickup port. The vacuum will pick up the screw.



Torque checker DLT1173A



Screw joint (with white rubber) DLW4540



*For DLV04C10L-AY SOFT fastening torque measurement

Screw joint (with black rubber) DLW4550



*For DLV10C10L-AY SOFT fastening torque measurement

Screw joint (with metal washer) DLW4560



*For HARD fastening torque measurement of both DLV04/10C10L-AY

For "K" Bit

Vacuum pickup DLP6640

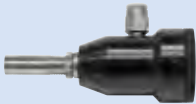

Vacuum pickup (for automatic machine) DLP6650



For "M" Bit

Vacuum pickup DLP6600



Vacuum pickup (for automatic machine) DLP6610



Flanged coupling (for automatic machine) DLW9015

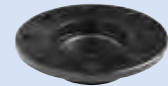

* Please see page 39 for details.

External Dimensions

•DLV04C/10C

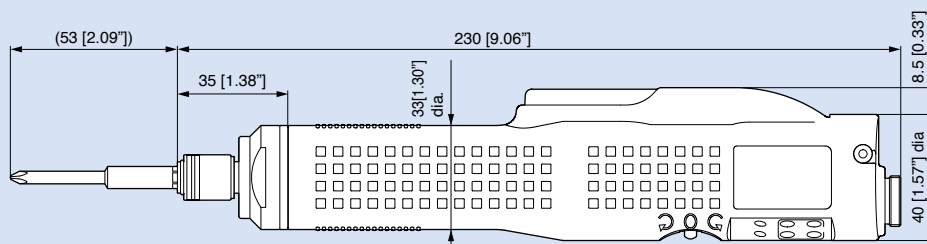

•DCC0101X

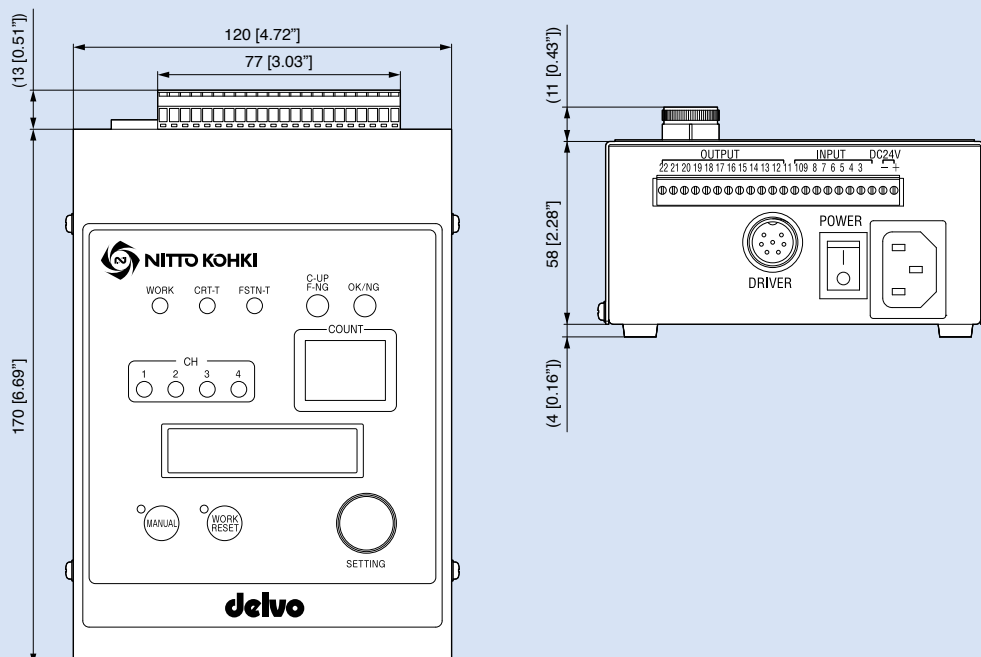

unit: mm [inch]

Low Voltage (DC)
 Brush motor **Brushless motor**
 Miniature screw Precision screw **Machine screw**
 2.6 - 8.0 mm

Lever Start Push to Start Low Voltage Brushless Motor Grounded Bit ESD Protection Soft Stop Variable Speed Soft Start

Delvo Brushless Type

S Series (Variable speed Type) Model DLV30S/45S/70S



Features

- Built-in brushless motor
- Automatic speed control function
- Built-in screw counting function
- Setting with the Remote Controller
- ESD (electrostatic discharge) protection structure

This screwdriver can deal with various fastening conditions.

Torque range **0.4 - 7.0 Nm**
 [3.5 - 62.0 lbf-in]



Built-in Automatic Speed Control Function

Low speed starting reduces the problems at start.

High speed feeding at middle improves efficiency and quality of screw fastening work.

Low speed fastening at finish reduces the problems at finish.

<Step 1>

<Step 2>

<Step 3>

Built-in the Functions of Screw Fastening Counter

- screw count setting
- fastening time setting, and fastening time measurement



Main LED mounted on the screwdriver

LEDs and Setting Buttons on the Screwdriver



Part Names of the Remote Controller



Specifications

		Low Speed	Standard	High Speed	Low Speed	Standard	Low Speed
Model	Bit	DLV30S06L-AY; K	DLV30S12L-AY; K	DLV30S20L-AY; K	DLV45S06L-AY; K	DLV45S12L-AY; K	DLV70S06L-AY; K
	Lever Start	DLV30S06P-AY; K	DLV30S12P-AY; K	DLV30S20P-AY; K	DLV45S06P-AY; K	DLV45S12P-AY; K	DLV70S06P-AY; K
Power Source		DEA0151N-AZ or DEA0241N-AZ		DEA0241N-AZ	DEA0151N-AZ or DEA0241N-AZ		DEA0241N-AZ
Torque Adjustment		Stepless					
Torque (Nm [lbf-in])	Low Torque Spring*1	0.4 - 1.6 [3.5 - 14.2]			2.0 - 4.5 [17.7 - 39.8]		3.8 - 7.0 [33.6 - 62.0]
	High Torque Spring*2	1.2 - 3.0 [10.6 - 26.6]					
Free Speed (min ⁻¹)		For the details, see separate setting range of speed and torque.					
Speed Level		Lv1 - Lv9 (Lv1: Min. Speed Lv9: Max. Speed decreases in a step-by-step manner)					
Power Consumption (W)		44					
Screw Size (mm)	Machine Screw	2.6 - 5.0			4.5 - 6.0		5.0 - 8.0
	Tapping Screw	2.5 - 4.0			4.0 - 5.0		4.5 - 6.0
Mass (g [lbs])		710 [1.57]			860 [1.90] (with pistol grip)		
Standard Accessories*3		• Bit NK35 × 2 × 7 × 75 • Low Torque Spring • Suspension Bail		• Connection Cord (DLW9073)		• Bit NK35 × 2 × 7 × 75 • Connection Cord (DLW9073) • Suspension Bail • Pistol Grip (DLW2300ESD)	

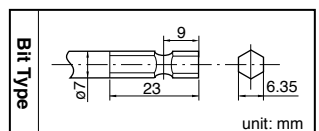

Please contact us for 5 mm bit type

*1: Standard Accessory
 *2: Built-in
 *3: The power cord is sold separately. Ask us for the required power cord when ordering.

Setting Range of Speed and Torque (for reference only)

Speed Level	Speed (min ⁻¹)	DLV30S06			DLV45S06			DLV70S06			Speed Level	Speed (min ⁻¹)	DLV30S12			DLV45S12			Speed Level	Speed (min ⁻¹)	DLV30S20		
		Torque (Nm [lbf-in])			Torque (Nm [lbf-in])			Torque (Nm [lbf-in])					Torque (Nm [lbf-in])			Torque (Nm [lbf-in])							
Lv1	160	0.4 - 1.3 [3.5 - 11.5]	-	-	-	-	-	-	-	-	Lv1	300	0.4 - 0.6 [3.5 - 5.3]	-	-	-	-	Lv1	500	0.4 [3.5]	-	-	
Lv2	220	0.4 - 2.0 [3.5 - 17.7]	2.0 - 2.4 [17.7 - 21.2]	-	-	-	-	-	-	-	Lv2	420	0.4 - 1.2 [3.5 - 10.6]	-	-	-	-	Lv2	690	0.4 - 0.8 [3.5 - 7.0]	-	-	
Lv3	280	0.4 - 2.7 [3.5 - 23.9]	2.0 - 3.5 [17.7 - 30.9]	3.8 [33.6]	-	-	-	-	-	-	Lv3	530	0.4 - 1.8 [3.5 - 15.9]	2.0 [17.7]	-	-	-	Lv3	880	0.4 - 1.2 [3.5 - 10.6]	-	-	
Lv4	340	0.4 - 3.0 [3.5 - 26.6]	2.0 - 4.5 [17.7 - 39.8]	3.8 - 4.6 [33.6 - 40.7]	-	-	-	-	-	-	Lv4	640	0.4 - 2.4 [3.5 - 21.2]	2.0 - 2.6 [17.7 - 23.0]	-	-	-	Lv4	1,060	0.4 - 1.6 [3.5 - 14.1]	-	-	
Lv5	410	0.4 - 3.0 [3.5 - 26.6]	2.0 - 4.5 [17.7 - 39.8]	3.8 - 5.4 [33.6 - 47.8]	-	-	-	-	-	-	Lv5	750	0.4 - 3.0 [3.5 - 26.6]	2.0 - 3.2 [17.7 - 28.3]	-	-	-	Lv5	1,250	0.4 - 2.0 [3.5 - 17.7]	-	-	
Lv6	470	0.4 - 3.0 [3.5 - 26.6]	2.0 - 4.5 [17.7 - 39.8]	3.8 - 6.2 [33.6 - 54.9]	-	-	-	-	-	-	Lv6	860	0.4 - 3.0 [3.5 - 26.6]	2.0 - 3.8 [17.7 - 33.6]	-	-	-	Lv6	1,440	0.4 - 2.4 [3.5 - 21.2]	-	-	
Lv7	530	0.4 - 3.0 [3.5 - 26.6]	2.0 - 4.5 [17.7 - 39.8]	3.8 - 7.0 [33.6 - 62.0]	-	-	-	-	-	-	Lv7	980	0.4 - 3.0 [3.5 - 26.6]	2.0 - 4.4 [17.7 - 38.9]	-	-	-	Lv7	1,630	0.4 - 2.8 [3.5 - 24.7]	-	-	
Lv8	590	0.4 - 3.0 [3.5 - 26.6]	2.0 - 4.5 [17.7 - 39.8]	3.8 - 7.0 [33.6 - 62.0]	-	-	-	-	-	-	Lv8	1,090	0.4 - 3.0 [3.5 - 26.6]	2.0 - 4.5 [17.7 - 39.8]	-	-	-	Lv8	1,810	0.4 - 3.0 [3.5 - 26.6]	-	-	
Lv9	650	0.4 - 3.0 [3.5 - 26.6]	2.0 - 4.5 [17.7 - 39.8]	3.8 - 7.0 [33.6 - 62.0]	-	-	-	-	-	-	Lv9	1,200	0.4 - 3.0 [3.5 - 26.6]	2.0 - 4.5 [17.7 - 39.8]	-	-	-	Lv9	2,000	0.4 - 3.0 [3.5 - 26.6]	-	-	

*Speed and torque are for reference only. The actual values depend on the materials to be fastened and size of screws. The values are not guaranteed.

Setting Range for Standard Models

The low speed level is effective in hard-to-fasten applications such as tapped holes in sheet metal, stainless steel, and plastic. The high speed level is effective in shortening the cycle time in an assembly line.

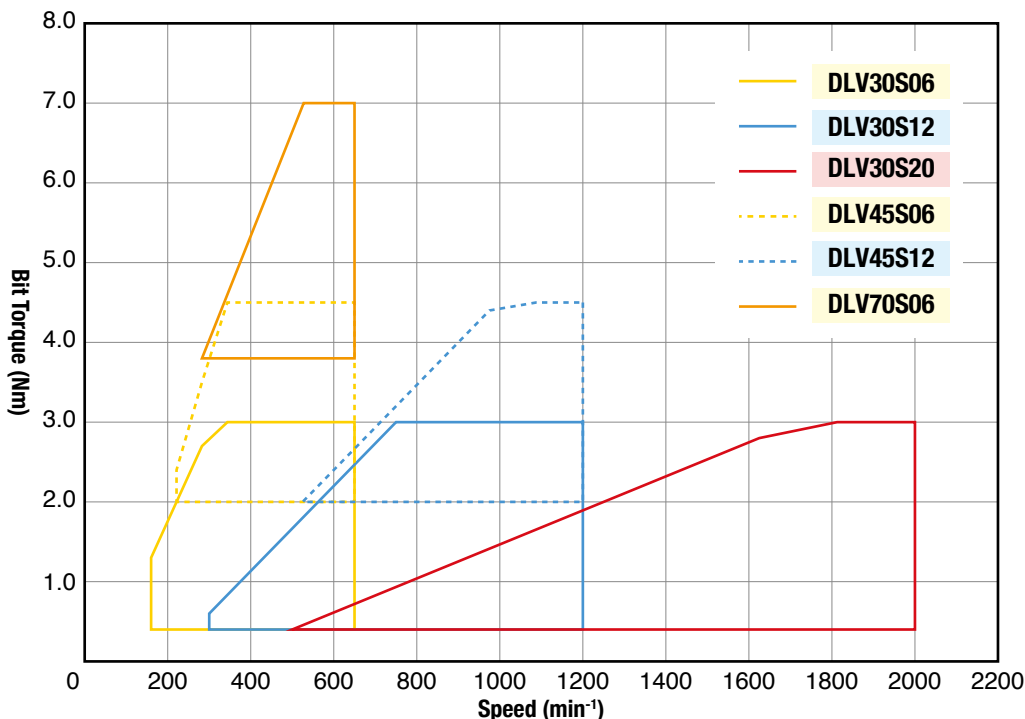

*Graphs are for reference only. The actual values depend on usage conditions.

Torque Diagrams (for reference)

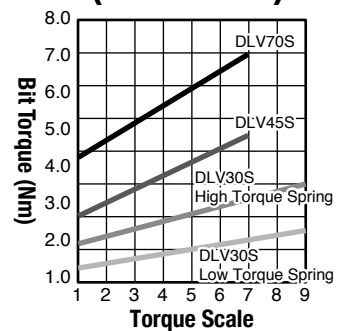

Equipped with the External Signal Connector

The screwdriver can accept an external signal or output a signal externally through the external signal connector.

Pin No.	Lead wire color	Signal	Input / output
1	Red	+24 V DC power (supplied from outside)	
2	White	Workpiece Signal	Input
3	Green	Reset signal	Input
4	Yellow	LINK-IN	Input
		Forced stop signal	
5	Brown	OK Signal	Output
6	Blue	NG Signal	Output
7	Gray	LINK-OUT	Output
		Channel switching signal	
8	Orange	Torque-up (count) signal	Output
9	Peach	Channel A	Input
10	Purple	Channel B	Input
11	Yellow Green	Channel C	Input
12	Black	0 V DC	

Lead wire colors are the ones used in the optional signal cable ass'y DLW9090.

*Either Pin No.4 or 7 must be selected, but not both.

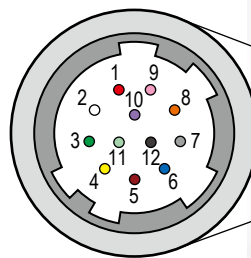

Optional Accessories

Power Supply DEA0151N-AZ DEA0241N-AZ		Grounded 3-Prong Power Cord DLW9220 DLW9240 DLW9250			Remote Controller RC1000
		North America	Europe	UK	
• Power cord is not included					
Signal Cable Ass'y DLW9090	Connection Cord DLW9073	Relay Cord (To connect DLW9073 and DLW9073) DLW9074			
*Standard accessory of screwdrivers					

External Dimensions

•DLV30S □P <p>48.5 [1.91"] 244.5 [9.63"] 7.5 [0.30"] 39.5 [1.56"] dia. 51 [2.01"] 4.5 [0.18"] 39.5 [1.56"]</p>	•DLV30S □L <p>46.5 [1.83"] 242.5 [9.55"] 7.5 [0.30"] 39.5 [1.56"] dia. 51 [2.01"] 4.5 [0.18"] 6.5 [0.26"] 39.5 [1.56"]</p>
•DLV45S □P <p>48.5 [1.91"] 244.5 [9.63"] 7.5 [0.30"] 39.5 [1.56"] dia. 51 [2.01"] 4.5 [0.18"] 39.5 [1.56"]</p>	•DLV45S □L <p>46.5 [1.83"] 242.5 [9.55"] 7.5 [0.30"] 39.5 [1.56"] dia. 51 [2.01"] 4.5 [0.18"] 6.5 [0.26"] 39.5 [1.56"]</p>
•DEA0151N-AZ <p>46 [1.81"] 2.5 [0.10"] 9 [0.35"] 8.5 [0.34"] 229 [9.02"] 200 [7.87"] 205 [8.07"] 89 [3.50"] 71 [2.80"] 4.3 [0.17"] 6.3 [0.25"] 7 [0.28"] 3.15 [0.12"] 4.3 [0.17"] 9.3 [0.37"] dia.</p>	•RC1000 <p>Infrared data transmission part 17 [0.67"] LCD Power Switch Various Buttons 120 [4.72"] 55 [2.17"]</p>
•DEA0241N-AZ <p>63 [2.48"] 2.5 [0.10"] 9 [0.35"] 8.5 [0.34"] 264 [10.40"] 235 [9.25"] 240 [9.45"] 98 [3.86"] 80 [3.15"] 4.3 [0.17"] 6.3 [0.25"] 7 [0.28"] 3.15 [0.12"] 4.3 [0.17"] 9.3 [0.37"] dia.</p>	

unit: mm [inch]

Low Voltage (DC)
 Brush motor **Brushless motor**
 Miniature screw Precision screw **Machine screw**
 2.6 - 8.0 mm

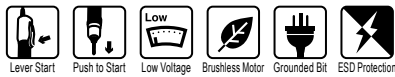

Delvo Brushless Type

A Series (Low Voltage Type) Model DLV30A/45A/70A



Features

Eco-friendly electric screwdrivers with built-in brushless motors in a low voltage (DC) profile

- Torque range from 0.4 to 7.0 Nm
- Speed range from 650 to 2000 min⁻¹
- Both the Lever Start and Push to Start type models are available
- Equipped with a torque adjustment ring cover
- Design conforms to the RoHS Directive and thus appeals to the environmentally conscious user
- Easily detachable Pistol Grip DLW2300 (TD00335) comes with the unit as a standard accessory (DLV45A/70A)
- ESD (electrostatic discharge) protection structure

Specifications

Model	Bit	Low Speed	Standard	High Speed	Low Speed	Standard	Low Speed	
		Lever Start	DLV30A06L-AY : K	DLV30A12L-AY : K	DLV30A20L-AY : K	DLV45A06L-AY : K	DLV45A12L-AY : K	DLV70A06L-AY : K
	Push to Start	DLV30A06P-AY : K	DLV30A12P-AY : K	DLV30A20P-AY : K	DLV45A06P-AY : K	DLV45A12P-AY : K	DLV70A06P-AY : K	
Power Source		DEA0151N-AZ or DEA0241N-AZ		DEA0241N-AZ	DEA0151N-AZ or DEA0241N-AZ		DEA0241N-AZ	
Torque Adjustment		Stepless						
Torque (Nm [lbf-in])	Low Torque Spring*1	0.4 - 1.6 [3.5 - 14.2]			2.0 - 4.5 [17.7 - 39.8]		3.8 - 7.0 [33.6 - 62.0]	
	High Torque Spring*2	1.2 - 3.0 [10.6 - 26.6]						
Free Speed (min ⁻¹)		650	1200	2000	650	1200	650	
Power Consumption (W)		44						
Screw Size (mm)	Machine Screw	2.6 - 5.0			4.5 - 6.0		5.0 - 8.0	
	Tapping Screw	2.5 - 4.0			4.0 - 5.0		4.5 - 6.0	
Mass (g [lbs])		690 [1.52]			840 [1.85] (with Pistol Grip)			
Standard Accessories		<ul style="list-style-type: none"> • Bit NK35 × 2 × 7 × 75 • Suspension Bail 		<ul style="list-style-type: none"> • Low Torque Spring • Connection Cord (DLW9073) 	<ul style="list-style-type: none"> • Bit NK35 × 2 × 7 × 75 • Suspension Bail • Connection Cord (DLW9073) • Pistol Grip (DLW2300ESD) 			

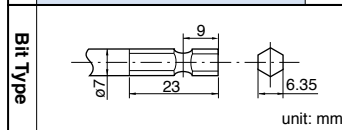

*1: Standard Accessory
 *2: Built-in.

Please contact us for 5 mm bit type.

Model	DEA0151N-AZ	DEA0241N-AZ
Input	100 - 240 V AC, 50/60 Hz, 60 W	
Output	40 V DC	
Maximum Rated Power (W)	150	240
Mass (kg)	0.56	0.9

*The power cord is sold separately. Ask us for the required power cord when ordering.

Torque Diagrams (for reference)

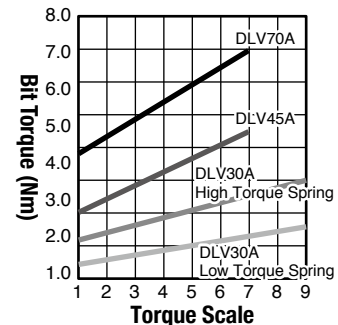

External Dimensions

•DLV30A□P

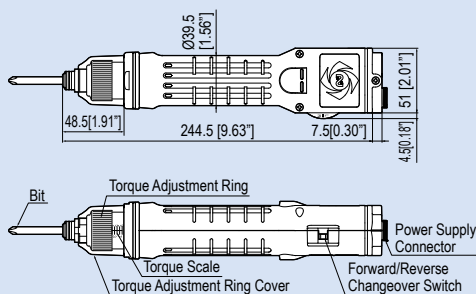

•DLV30A□L

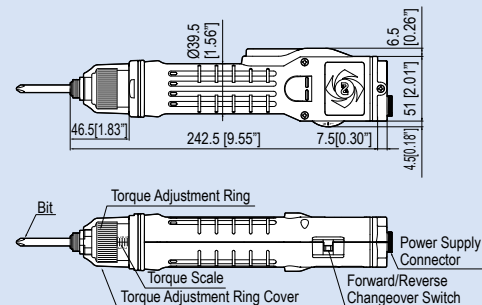

•DLV45A□P/DLV70A□P

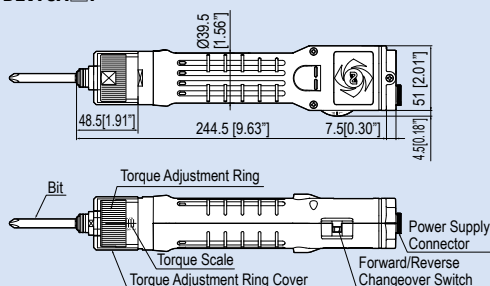

•DLV45A□L/DLV70A□L

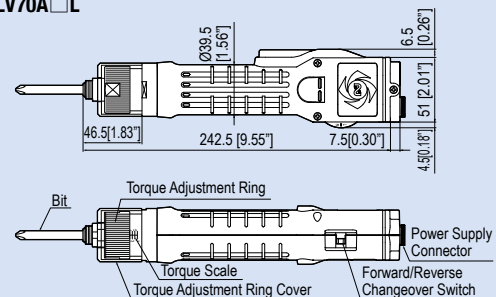

unit: mm [inch]

(See page 12 for external dimensions of power supply DEA0151N-AZ and DEA0241N-AZ)

Transformerless (AC)
 Brush motor **Brushless motor**
 Miniature screw Precision screw **Machine screw**
 2.6 - 8.0 mm



Delvo Brushless Type

A Series (Transformerless Type) Model DLV30A/45A/70A

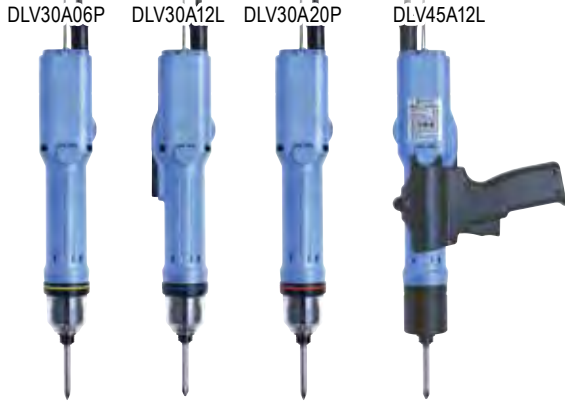

Features

Eco-friendly electric screwdrivers with built-in brushless motors in a transformerless profile

- Torque range from 0.4 to 7.0 Nm
- Speed range from 650 to 2000 min⁻¹
- Both the Lever Start and Push to Start type models are available
- Equipped with a torque adjustment ring cover
- Design conforms to the RoHS Directive and thus appeals to the environmentally conscious user
- Easily detachable Pistol Grip DLW2300 (TD00335) comes with the unit as a standard accessory (DLV45A/70A)

Specifications

		Low Speed	Standard	High Speed	Low Speed	Standard	Low Speed
Model	Bit	DLV30A06L-AB : K	DLV30A12L-AB : K	DLV30A20L-AB : K	DLV45A06L-AB : K	DLV45A12L-AB : K	DLV70A06L-AB : K
	Lever Start	DLV30A06L-AB : K	DLV30A12L-AB : K	DLV30A20L-AB : K	DLV45A06L-AB : K	DLV45A12L-AB : K	DLV70A06L-AB : K
	Push to Start	DLV30A06P-AB : K	DLV30A12P-AB : K	DLV30A20P-AB : K	DLV45A06P-AB : K	DLV45A12P-AB : K	DLV70A06P-AB : K
Input Voltage		230 V AC, 50/60 Hz					
Torque Adjustment		Stepless					
Torque (Nm [lbf-in])	Low Torque Spring*1	0.4 - 1.6 [3.5 - 14.2]			2.0 - 4.5 [17.7 - 39.8]		3.8 - 7.0 [33.6 - 62.0]
	High Torque Spring*2	1.2 - 3.0 [10.6 - 26.6]					
Free Speed (min ⁻¹)		650	1200	2000	650	1200	650
Power Consumption (W)		Approx. 45					
Screw Size (mm)	Machine Screw	2.6 - 5.0			4.5 - 6.0		5.0 - 8.0
	Tapping Screw	2.5 - 4.0			4.0 - 5.0		4.5 - 6.0
Mass (g [lbs])		700 [1.54]					
Standard Accessories		• Bit No.2 × 7 × 75 • Suspension Bail • Low Torque Spring			• Bit No.2 × 7 × 75 • Suspension Bail		

Bit Type

unit: mm

Plug Shape

Europe

*1: Standard Accessory
 *2: Built-in.

Torque Diagrams (for reference)

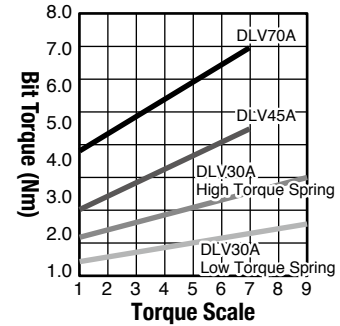

Please contact us for 5 mm bit type.

Optional Accessories

Pistol Grip
DLW2300ESD

Torque Adjustment Ring Cover

External Dimensions

•DLV30A□P

•DLV30A□L

•DLV45A□P/70A06P

•DLV45A□L/70A06L

unit: mm [inch]

Low Voltage (DC)
 Brush motor **Brushless motor**
 Miniature screw **Precision screw** Machine screw
1.0 - 4.0 mm



Delvo Brushless Type

DLV02/12/16 Series



Features

Brushless motors are incorporated for maximum tool life

- Ergonomic grip offers greater operator comfort and increased maneuverability
- Grounded bit system standard
- Clear plastic torque adjustment cover provided as standard accessory (DLV02/12/16SL-CKE)
- ESD (electrostatic discharge) protection structure (DLV02/12/16SL-BKE)
- Compliant with CE standards
- Controllers feature an overload detection function. When an overload is detected, the controller stops the screwdriver. Operation can be resumed after the screwdriver is unloaded, and the lever released (DLC16S)
- Universal input voltage from 100 to 240 V AC for easy installation (DLC16S)
- Variable speed adjustment enables you to select optimum screw tightening speed (DLC16S)

Specifications

Model	Standard Type	DLV02SL-CKE	DLV12SL-CKE	DLV16SL-CKE	
	ESD Protection Type	DLV02SL-BKE	DLV12SL-BKE	DLV16SL-BKE	
Electric Screwdriver	Starting Method	Lever Start			
	Input Voltage	20 - 30 V DC			
	Torque Adjustment	Stepless			
	Torque (Nm [lbf-in])	0.03 - 0.2 [0.3 - 1.8]	0.15 - 1.2 [1.3 - 10.6]	0.2 - 1.6 [1.8 - 14.2]	
	Free Speed (min ⁻¹)	700 - 1000			
	Power Consumption (W)	48			
	Screw Size (mm)	Machine Screw	1.0 - 2.2	1.4 - 3.0	2.2 - 4.0
		Tapping Screw	1.0 - 2.0	1.4 - 2.6	2.0 - 3.0
Mass (g [lbs])	470 [1.04]				
Bit Type					

Model	DLC16S-WGB
Input Voltage	100 - 240 V AC, 50/60 Hz
Output Voltage	20 - 30 V DC
Function	Speed Control
Mass (g [lbs])	380 [0.84]

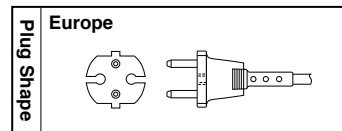

Standard Accessories

Model	DLV02	DLV12	DLV16
Bit	No.0 x 3.8 x 50	1	-
	No.1 x 3.8 x 50	1	1
	No.2 x 4.5 x 50	-	1
Connection Cable	1	1	1

Torque Diagrams (for reference)

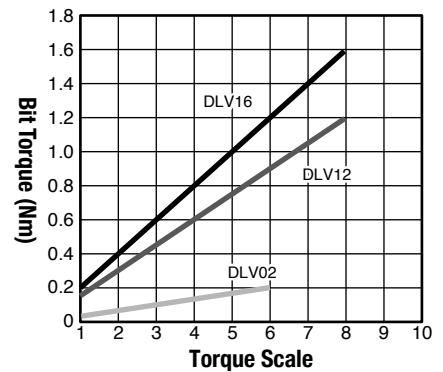

External Dimensions

•DLV02/12/16SL-CKE

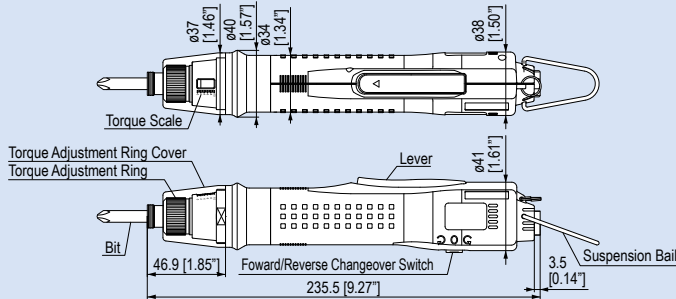

•DLC16S-WGB

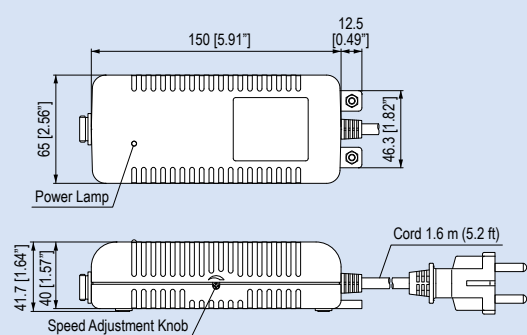

•DLV02/12/16SL-BKE

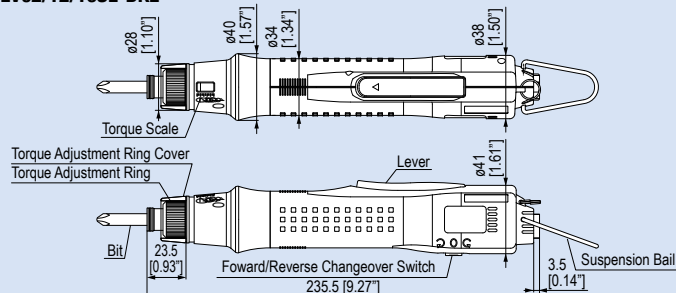

unit: mm [inch]

Low Voltage (DC)
 Brush motor / Brushless motor
 Miniature screw / Precision screw / Machine screw
 1.0 - 2.6 mm



Clean room adaptation
 DLV7419A
 DLV7419HA
 DLV7429A



DLV7400A Series CE



Features

The light and compact body reduces operator fatigue

- Reduces shock applied to workpieces when fastening screws
- ESD (electrostatic discharge) protection structure
- Lightweight (Standard type 230 g, Clean room type 275 g)
- The Clean Room Type complies with Class 3 Clean Room Rating
- The controller can adjust speed (Screw-fastening speed can be set to suit specific fastening conditions)
- The controller provides a soft start function
- The initial speed at screwdriver startup can therefore be slowed down, effectively preventing screw heads from being scratched
- The built-in coreless motor achieves reduced inertia
- Torque accuracy is within a top-ranked worldwide level (Based on measurements at our laboratory)
- Compliant with CE standards
- Use of the Screw Fastening Counter prevents human fastening errors and enhances accurate fastening control (No CE marking or CCC applied)
- Screw Fastening Counter Model DLR5640-WN works in conjunction with any dedicated SPC-type electric screwdrivers

Specifications

Model	Standard Type	DLV7410A-BME	DLV7410HA-BME	DLV7420A-BME
	Clean Room Type	DLV7419A-BME	DLV7419HA-BME	DLV7429A-BME
Starting Method	Lever Start			
Input Voltage	40 V DC			
Torque Adjustment	Stepless			
Torque (Nm [lbf-in])	0.02 - 0.2 [0.2 - 1.8]		0.15 - 0.4 [1.3 - 3.5]	
Free Speed (min ⁻¹)	500 - 750	700 - 1000	450 - 600	
Power Consumption (W)	Approx. 10			
Screw Size (mm)	Machine Screw	1.0 - 2.3		1.6 - 2.6
	Tapping Screw	1.0 - 2.0		1.4 - 2.3
Mass (g [lbs])	Standard Type 230 [0.51] / Clean Room Type 275 [0.61]			

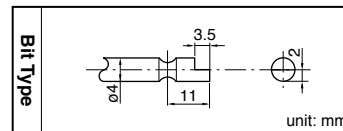

Model	DLC1110-EN	DLC1110-FE	DLC1110-GE	DLC1110-HE	DLC1213A-GGB*1	DLC1213A-HEB*1
Features	Standard	Standard	Standard	With CE Mark	With CE Mark	With CE Mark
Input Voltage	100 V AC, 50/60 Hz	115 V AC, 50/60 Hz	220 V AC, 50/60 Hz	230 V AC, 50/60 Hz	240 V AC, 50/60 Hz	230 V AC, 50/60 Hz
Control Function	Soft Start, Speed Control, ESD Protected					
Plug Shape	USA	USA	UK	Europe	UK	Europe
Mass (g [lbs])	900 [1.98]			2300 [5.07]		

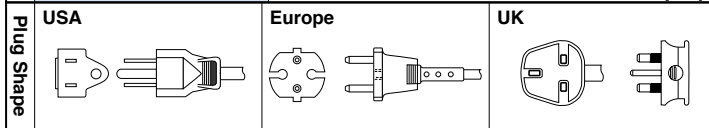

*1: An optional cord is required to connect with this model. Neither DLC1213A-GG nor DLC1213A-HE can be used with the DLV7400A series.

Model DLC1213A-GGB or DLC1213A-HEB + Cord DLW9072

Standard Accessories

Model	DLV7410A/DLV7410HA	DLV7420A	DLV7419A/DLV7419HA	DLV7429A
Bit	No.0 x 1.8 x 44	1	-	1
	No.0 x 2.5 x 44	1	1	1
	No.1 x 4 x 44	-	1	-
Connection Cable DLW9070	1	1	1	1
Spring for Low Torque	1	-	1	-
Suspension Bail	1	1	1	1
Sleeve for Vacuum DLS2124	-	-	1	1

Optional Accessories



* Please see page 39 for details.

Shock value

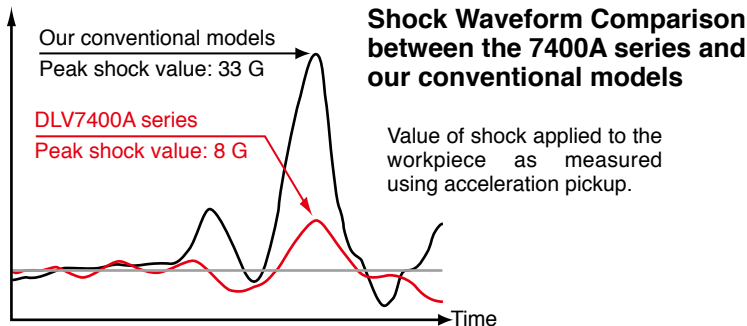

Torque Diagrams (for reference)

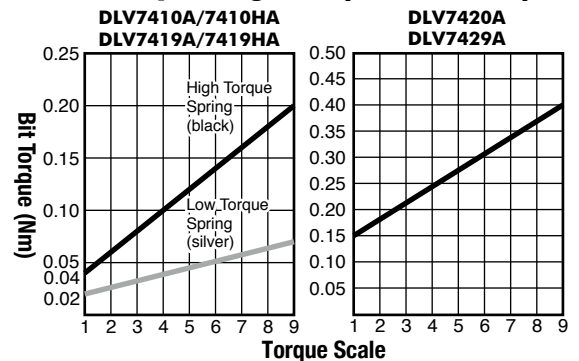

External Dimensions

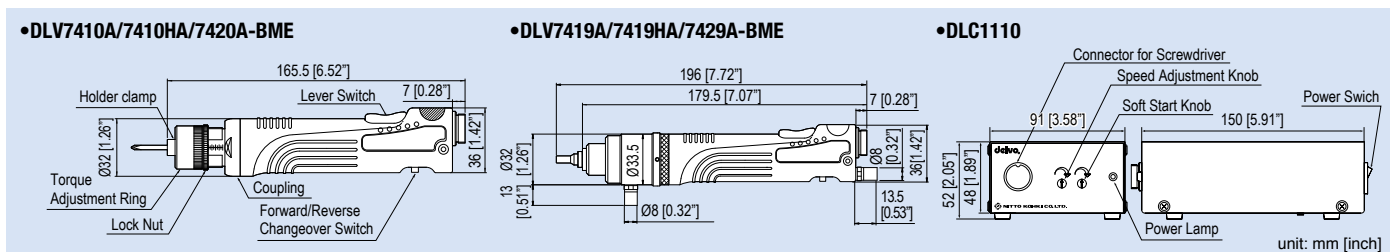

DLV5700 Series Non-CE



Features

For quality improvement and productivity enhancement

- Grounded bit installation mechanism
- ESD (electrostatic discharge) protection structure
- Low-shock for tightening (30 % less of standard models)
- Low swing bit mechanism
- Ergonomic design
- High-performance DC motor
- New clutch mechanism

Specifications

Model	DLV5720	DLV5720H	DLV5740	DLV5740H	DLV5750
Starting Method	Lever Start				
Input Voltage	40 V DC			36 V DC	
Torque Adjustment	Stepless				
Torque (Nm [lbf-in])	0.02 - 0.2 [0.2 - 0.18]		0.15 - 0.4 [1.3 - 3.5]		0.1 - 0.55 [0.9 - 4.9]
Free Speed (min ⁻¹)	500 - 750	700 - 1000	450 - 600	1200 - 1800	670 - 1000
Power Consumption (W)	Approx. 10			Approx. 35	
Screw Size (mm)	Machine Screw	1.0 - 2.3		1.6 - 2.6	
	Tapping Screw	1.0 - 2.0		1.4 - 2.3	
Mass (g [lbs])	230 [0.51]			300 [0.66]	
Standard Accessories	<ul style="list-style-type: none"> • Bit No.0 × 1.8 × 44 • Bit No.0 × 2.5 × 44 • Connection Cable (1.5 m)DLW9081 • Suspension Bail • Spring for Low Torque 		<ul style="list-style-type: none"> • Bit No.0 × 2.5 × 44 • Bit No.1 × 4 × 44 		<ul style="list-style-type: none"> • Connection Cable (1.5 m)DLW9081 • Suspension Bail

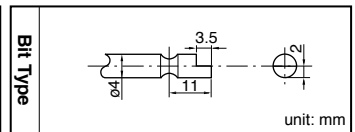

Model	DLC0350E	DLC0350F	DLC0350G	DLC0950E	DLC0950G
Input Voltage	100 V AC, 50/60 Hz	115 V AC, 50/60 Hz	230 V AC, 50/60 Hz	100 V AC, 50/60 Hz	230 V AC, 50/60 Hz
Plug Shape	USA		UK	USA	
Mass (g [lbs])	900 [1.98]			1800 [3.97]	

Optional Accessories



Torque Diagrams (for reference)

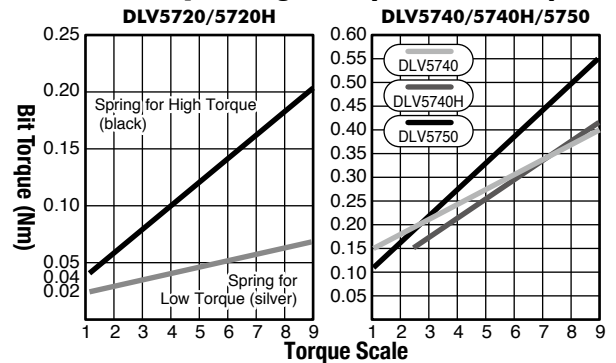

External Dimensions

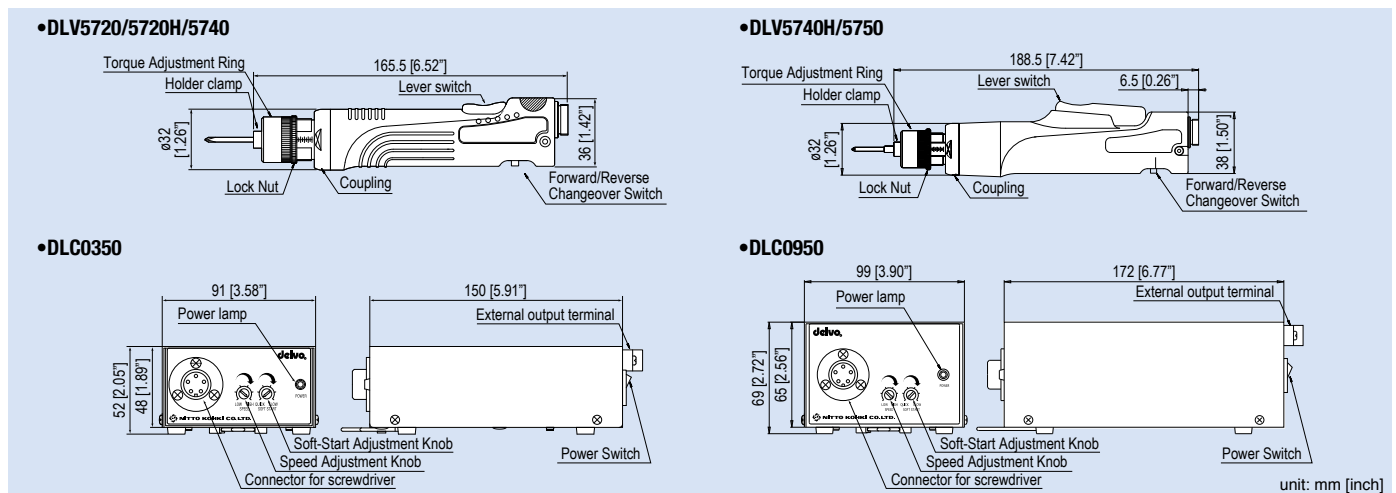

Low Voltage (DC)
 Brush motor Brushless motor
 Miniature screw Precision screw Machine screw
 1.0 - 2.6 mm

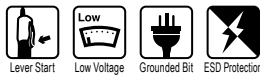

DLV5800 Series Non-CE

DLV5800 series

DLC0250E



DLC0350



Features

In response to the needs of cell production system, space-saving delvo screwdrivers are released. Controller is designed for emphasis on space-saving size and lightness.

- Clear disengagement of clutch (low-shock mechanism unavailable)
- Grounded bit installation mechanism
- ESD (electrostatic discharge) protection structure
- New lever is adopted
- Low swing bit mechanism
- Low voltage transformerless controller

Specifications

Model	DLV5820	DLV5820H	DLV5840
Starting Method	Lever Start		
Input Voltage	40 V DC		
Torque Adjustment	Stepless		
Torque (Nm [lbf-in])	0.02 - 0.2 [0.2 - 1.8]		0.15 - 0.4 [1.3 - 3.5]
Free Speed (min ⁻¹)	750	1000	600
Power Consumption (W)	Approx. 10		
Screw Size (mm)	Machine Screw	1.0 - 2.3	1.6 - 2.6
	Tapping Screw	1.0 - 2.0	1.4 - 2.3
Mass (g [lbs])	230 [0.51]		
Cord Length (m)	1.5 (with connector)		
Grounding Bit Feature	Equipped as standard		
Standard Accessories	<ul style="list-style-type: none"> • Bit No.0 × 1.8 × 44 • Bit No.0 × 2.5 × 44 • Suspension Bail 	<ul style="list-style-type: none"> • Connection Cable (1.5 m) • Spring for Low Torque (Silver) 	<ul style="list-style-type: none"> • Bit No.0 × 2.5 × 44 • Bit No.1 × 4 × 44 • Suspension Bail • Connection Cable (1.5 m)

Model	DLC0250E
Input Voltage	100 V AC, 50/60 Hz
Function	Grounded Bit Installation Mechanism
Mass (g [lbs])	300 [0.66]
Case Material	Antistatic material

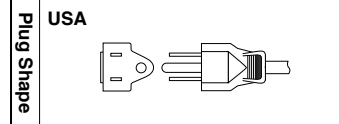

* Electric screwdrivers DLV5800 series can be also used with DLC0350.

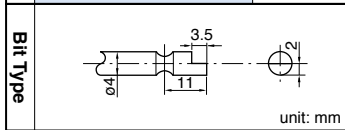

Optional Accessories

Sleeve

Vacuum Pickup
DLP5300 (TD04342)

Torque Adjustment Ring Cover
DLW5700 (TD02875)

This minimizes tampering or accidental turning of the torque adjustment ring once the torque is set.

* Please see page 39 for details.

Torque Diagrams (for reference)

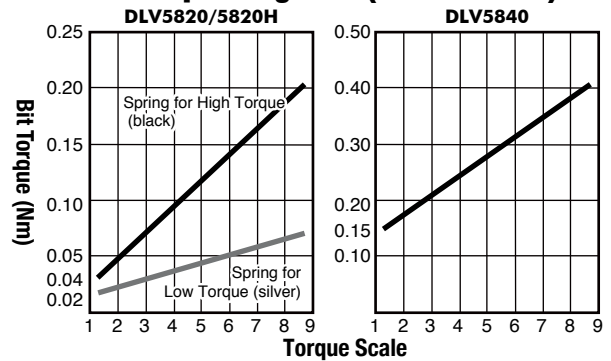

External Dimensions

•DLV5820/5820H/5840

•DLC0250E

unit: mm [inch]

Low Voltage (DC)
 Brush motor / Brushless motor
 Miniature screw / Precision screw / Machine screw
 1.0 - 3.5 mm

Lever Start / Low Voltage / Variable Speed / Soft Start

Clean room adaption
 DLV7325 / DLV7335



DLV7300 Series

DLV7313/7323/7333



DLV7325/7335



DLC1213A



Features

- The dedicated controller realizes high-accuracy screw tightening
 - High repeatable torque accuracy
 - The controller provides a soft start function. The initial speed at screwdriver startup can therefore be slowed down, effectively preventing screw heads from being scratched.
 - Variable speed adjustment enables to select optimum screw tightening speed.
 - DLV7325, DLV7335 meet Class 5*1 Clean Room standards
- *1: Based on Nitto Kohki's standard of measurement

Specifications

Model	Bit Shank: \varnothing 4 mm Bit Shank: Hex. 6.35 mm	Standard			Clean Room Use	
		DLV7313-CME	DLV7323-CME	DLV7333-CME	DLV7325-CME*2	DLV7335-CME*2
Starting Method		Lever Start				
Input Voltage		36 V DC				
Torque Adjustment		Stepless				
Torque (Nm [lbf-in])		0.03 - 0.15 [0.3 - 1.3]	0.05 - 0.5 [0.4 - 4.4]	0.3 - 1.2 [2.7 - 10.6]	0.05 - 0.5 [0.4 - 4.4]	0.3 - 1.2 [2.7 - 10.6]
Free Speed (min ⁻¹)		700 - 1000		500 - 700	700 - 1000	500 - 700
Power Consumption (W)		Approx. 35				
Screw Size (mm)	Machine Screw	Up to 2.0	1.0 - 3.0	2.0 - 3.5	1.0 - 3.0	2.0 - 3.5
	Tapping Screw	Up to 1.7	1.2 - 2.6	2.0 - 3.0	1.2 - 2.6	2.0 - 3.0
Mass (g [lbs])		350 [0.77]			400 [0.88]	

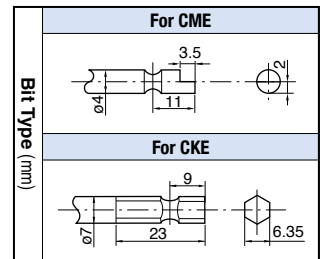

*2: Vacuum pump for suction of screw is available as option. See page 31 for details of the vacuum pump.

Model	Features	Input Voltage	Control Function	Plug Shape	Mass (g [lbs])
DLC1213A-EN	Standard	100 V AC, 50/60 Hz	Soft start, Speed control	Asia	2300 [5.07]
DLC1213A-FE*3	Standard	115 V AC, 50/60 Hz		UK	
DLC1213A-GE	Standard	220 V AC, 50/60 Hz		Europe	
DLC1213A-GG	With CE Mark	230 V AC, 50/60 Hz		UK	
DLC1213A-GGU	With CE Mark	230 V AC, 50/60 Hz		Without Plug	
DLC1213A-HE	Standard	240 V AC, 50/60 Hz			

*3: This model is made to order.

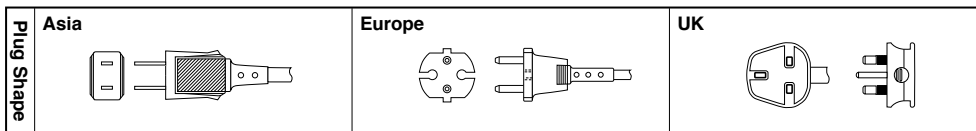

Torque Diagrams (for reference)

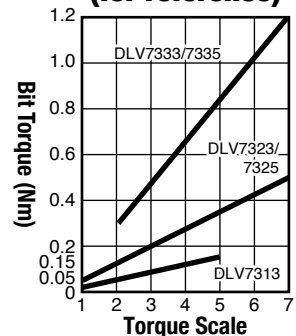

Standard Accessories

Model	DLV7313 -CME	DLV7323 -CME	DLV7333 -CME	DLV7323 / 31 / 33-CKE	DLV7325 -CME	DLV7335 -CME	DLV7325 / 35-CKE	
Bit	No.0 x 1.8 x 44	1	-	-	-	-	-	
	No.0 x 2.5 x 44	1	1	-	-	1	-	
	No.1 x 3 x 44	-	-	1	-	-	1	
	No.1 x 4 x 44	-	1	-	-	1	-	
	No.1 x 7 x 50	-	-	-	1	-	-	
	No.2 x 4 x 44	-	-	1	-	-	1	
	No.2 x 4.5 x 50	-	-	-	-	-	-	1
	No.2 x 7 x 50	-	-	-	1	-	-	-
Sleeve	DLS2124	-	-	-	1	-	-	
	DLS2127	-	-	-	1	1	-	
	DLS2130	-	-	-	1	1	-	
	DLS2134	-	-	-	-	1	-	
	DLS2135	-	-	-	-	-	1	
Suspension Bail				1				

Optional Accessories



This minimizes tampering or accidental turning of the torque adjustment ring once the torque is set.

Torque Adjustment Ring Cover for DLV7303 DLW5500 (TD00333)

External Dimensions

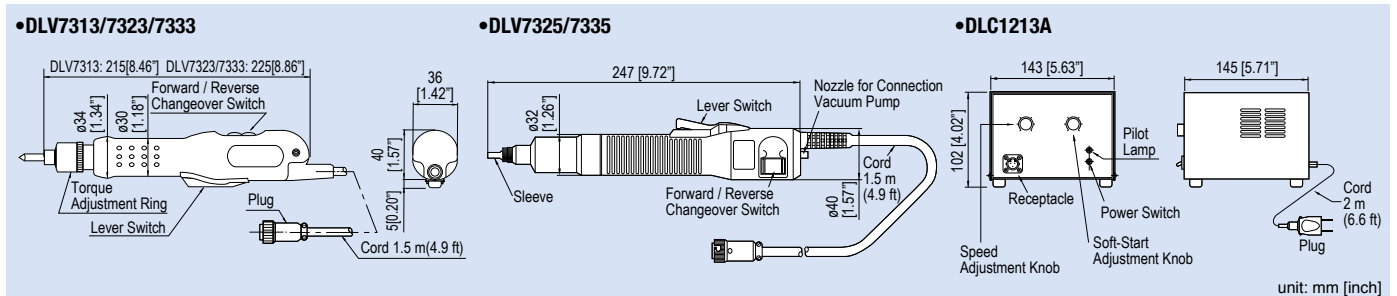

Low Voltage (DC)
 Brush motor Brushless motor
 Miniature screw Precision screw Machine screw
 1.0 - 3.5 mm



DLV7300-BME/BKE Series



Features

Workpiece-conscious electric screwdrivers

- Statistic electricity buildup is prevented to protect workpieces from electrostatic discharge
- Minimal impact in screw tightening protects workpieces from damaging and enables stable screw tightening
- ESD (electrostatic discharge) protection structure
- Meet Class 5*1 or more Clean Room standards

*1: Based on Nitto's standard of measurement

Specifications

Model	Bit Shank: ϕ 4 mm Bit Shank: Hex. 6.35 mm	ESD		ESD / Low Shock			
		DLV7321-BME*2	DLV7331-BME*2	DLV7319-BME*2	DLV7329-BME*2	DLV7339-BME	DLV7349-BME*2
Starting Method		Lever Start					
Input Voltage		36 V DC					
Torque Adjustment		Stepless					
Torque (Nm [lbf-in])		0.05 - 0.5 [0.4 - 4.4]	0.3 - 1.2 [2.7 - 10.6]	0.2 - 0.4 [1.8 - 3.5]	0.25 - 0.4 [2.2 - 4.9]	0.45 - 0.95 [4.0 - 8.4]	0.55 - 1.2 [4.9 - 10.6]
Free Speed (min ⁻¹)		700 - 1000	500 - 700	700 - 1000		500 - 700	
Power Consumption (W)		Approx. 35					
Screw Size (mm)	Machine Screw	1.0 - 3.0	2.0 - 3.5	2.0 - 3.0		3.0 - 3.5	
	Tapping Screw	1.2 - 2.6	2.0 - 3.0	2.0 - 2.6		2.6 - 3.0	
Mass (g [lbs])		350 [0.77]		400 [0.88]			
Bit Type (mm)	For BME	For BKE		*2: These models are made to order.			

Model	Features	Input Voltage	Plug Shape	Control	Mass (g [lbs])
DLC1213A-ENB	Standard	100 V AC, 50/60 Hz	USA	Grounding, Soft Start, Speed Control	2300 [5.07]
DLC1213A-FEB*3	Standard	115 V AC, 50/60 Hz	USA		
DLC1213A-GGB	With CE mark	230 V AC, 50/60 Hz	Europe		
DLC1213A-HEB	Standard	240 V AC, 50/60 Hz	UK		

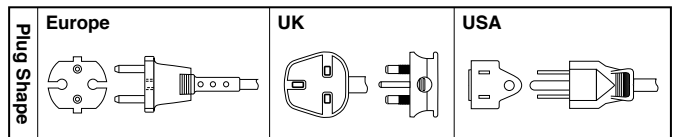

*3: This model is made to order.

Measurement Point	Conventional Product		DLV7300-B□E
	Handle	Static Electricity (V)	350
	Surface Resistance (Ω)	more than 10^{13}	10^4
Lever Switch	Static Electricity (V)	350	2
	Surface Resistance (Ω)	more than 10^{13}	10^4
Forward / Reverse Switch	Static Electricity (V)	25	2
	Surface Resistance (Ω)	more than 10^{13}	10^{10}
Power Cable	Static Electricity (V)	110	5
	Surface Resistance (Ω)	more than 10^{13}	10^{10}

Part	Material
Handle Lever Switch	Synthetic resin with carbon fiber
Power Cable	Anti-static material

* Measurement conditions (Temperature: 22 °C Humidity: 66 %)
 (1) Static electricity • Earth the measurement equipment and measuring person.
 • Grip the screwdriver five times using Ansel Edmont electronic control glove.
 • Turn on the switch of the screwdriver. • Measure each part of the screwdriver using electronic measurement equipment manufactured by Shishido electrostatic Ltd.
 (2) Surface resistance • Measure using Simco Japan surface resistivity measurement equipment.

Standard Accessories

Model	DLV7319/29 -BME	DLV7339/49 -BME	DLV7321 -BME	DLV7331 -BME	DLV7321/31 -BKE	
Bit	No.0 × 2.5 × 44	1	-	1	-	
	No.1 × 3 × 44	-	1	-	1	
	No.1 × 4 × 44	1	-	1	-	
	No.1 × 7 × 50	-	-	-	-	1
	No.2 × 4 × 44	-	1	-	1	-
	No.2 × 7 × 50	-	-	-	-	1
Sleeve	DLS2124	1	-	-	-	
	DLS2127	1	1	-	-	
	DLS2130	1	1	-	-	
	DLS2134	-	1	-	-	
Suspension Bail	1					

Torque Diagrams (for reference)

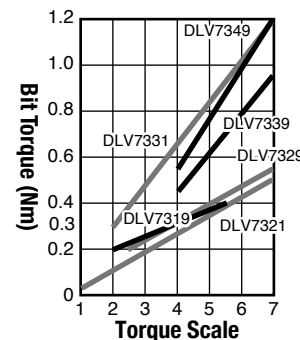

External Dimensions

•DLV73□1/DLV73□9

•DLC1213A-□□B

unit: mm [inch]

Low Voltage (DC)
 Brush motor / Brushless motor
 Miniature screw / Precision screw / Machine screw
 2.6 - 6.0 mm



DLV7500/8500 Series



Features

Low vibration, low noise, and easy gripping in a compact design

- The easily visible torque reach light goes on when the set torque is reached
- The combination of an advanced clutch design and the auto-stop circuit assures torque accuracy
- The long life motor with a yoke made of advanced materials further assures a long service life
- Compliant with CE standard
- ESD (electrostatic discharge) protection structure (DLV7500/8500-BKE)

Specifications

Model	Standard Type	Standard		High Torque		Standard		High Torque			
	ESD Protection Type	DLV7530-MKE	DLV7540-MKE	DLV7550-MKE	DLV8530-MKE	DLV8540-MKE	DLV8550-MKE	DLV8530-BKE	DLV8550-BKE		
Electric Screwdriver	Starting Method	Lever Start				Push to Start					
	Input Voltage	59 V DC									
	Torque Adjustment	Stepless									
	Torque (Nm [lbf-in])	0.5 - 1.7 [4.4 - 15.1]	1.2 - 2.7 [10.6 - 23.9]	2.0 - 4.5 [17.7 - 39.8]	0.5 - 1.7 [4.4 - 15.1]	1.2 - 2.7 [10.6 - 23.9]	2.0 - 4.5 [17.7 - 39.8]	0.5 - 1.7 [4.4 - 15.1]	1.2 - 2.7 [10.6 - 23.9]	2.0 - 4.5 [17.7 - 39.8]	
	Free Speed (min ⁻¹)	1100	700	500	1100	700	500	1100	700	500	
	Screw Size (mm)	Machine Screw	2.6 - 4.0	3.5 - 5.0	4.5 - 6.0	2.6 - 4.0	3.5 - 5.0	4.5 - 6.0	2.6 - 4.0	3.5 - 5.0	4.5 - 6.0
		Tapping Screw	2.3 - 3.5	3.0 - 4.0	4.0 - 5.0	2.3 - 3.5	3.0 - 4.0	4.0 - 5.0	2.3 - 3.5	3.0 - 4.0	4.0 - 5.0
	Mass (g [lbs])	650 [1.43]		750 [1.65]		650 [1.43]		750 [1.65]			
	Bit Type										
		unit: mm									

Measurement Point	Conventional Product	DLV7500/8500-BKE	
Handle	Static Electricity (V)	350	5
	Surface Resistance (Ω)	more than 10 ¹³	10 ⁴
Lever Switch	Static Electricity (V)	350	2
	Surface Resistance (Ω)	more than 10 ¹³	10 ⁴
Forward / Reverse Switch	Static Electricity (V)	25	2
	Surface Resistance (Ω)	more than 10 ¹³	10 ⁴
Connection Cable	Static Electricity (V)	110	5
	Surface Resistance (Ω)	more than 10 ¹³	10 ¹⁰

Part	Material
Handle Lever Switch	Synthetic resin with carbon fiber
Power Cable	Anti-static material

* Measurement conditions (Temperature: 22 °C Humidity: 66 %)
 (1) Static electricity • Earth the measurement equipment and measuring person.
 • Grip the screwdriver five times using Ansel Edmont electronic control glove.
 • Turn on the switch of the screwdriver. • Measure each part of the screwdriver using electronic measurement equipment manufactured by Shishido electrostatic Ltd.
 (2) Surface resistance • Measure using Simco Japan surface resistivity measurement equipment.

Standard Accessories

Model	DLV7530 / 7540 / 8530 / 8540	DLV7550 / 8550	
Bit	No.1 × 7 × 75	1	-
	No.2 × 7 × 75	1	1
	No.3 × 7 × 50	-	1
Spare Carbon Brush	2		
Connection Cable	1		
Suspension Bail	1		

Torque Diagrams (for reference)

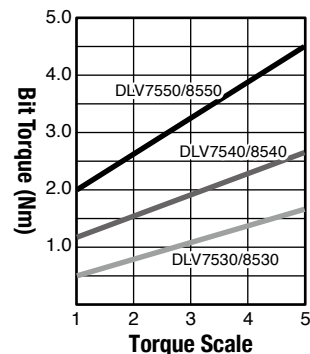

External Dimensions

DLV7500 series

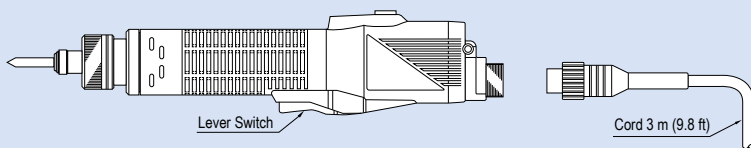

DLV8500 series

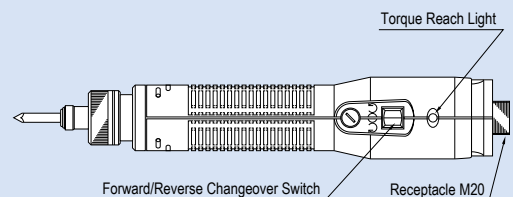
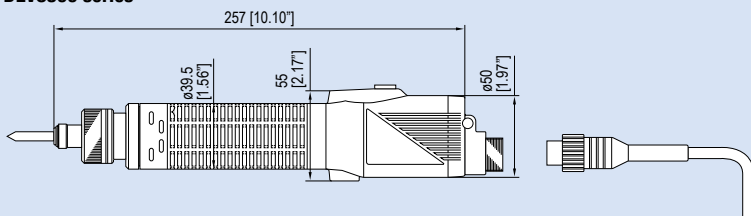

unit: mm [inch]



DLC4511-GGB



DLR1510-JE

Specifications

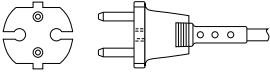
Model	DLC4511-GGB	DLR1510-JE	
Controller	Function	Stepless speed adjustment 80 - 100 % Soft start: adjustable time setting of slow speed (max. 3 sec.) External output signals: start and torque up Electro-static discharge(ESD) control	Screw counting: OK lamp and buzzer for notification Variable non-operation time Setting protection by key lock switch Setting by touch switch for easy operation External output signals: Start, Torque up, Count up & Cycle OK
	Input Voltage	230 V AC, 50/60 Hz	
	Mass (g [lbs])	3500 [7.72]	5100 [11.24]
	Plug Shape	Europe 	

External Dimensions

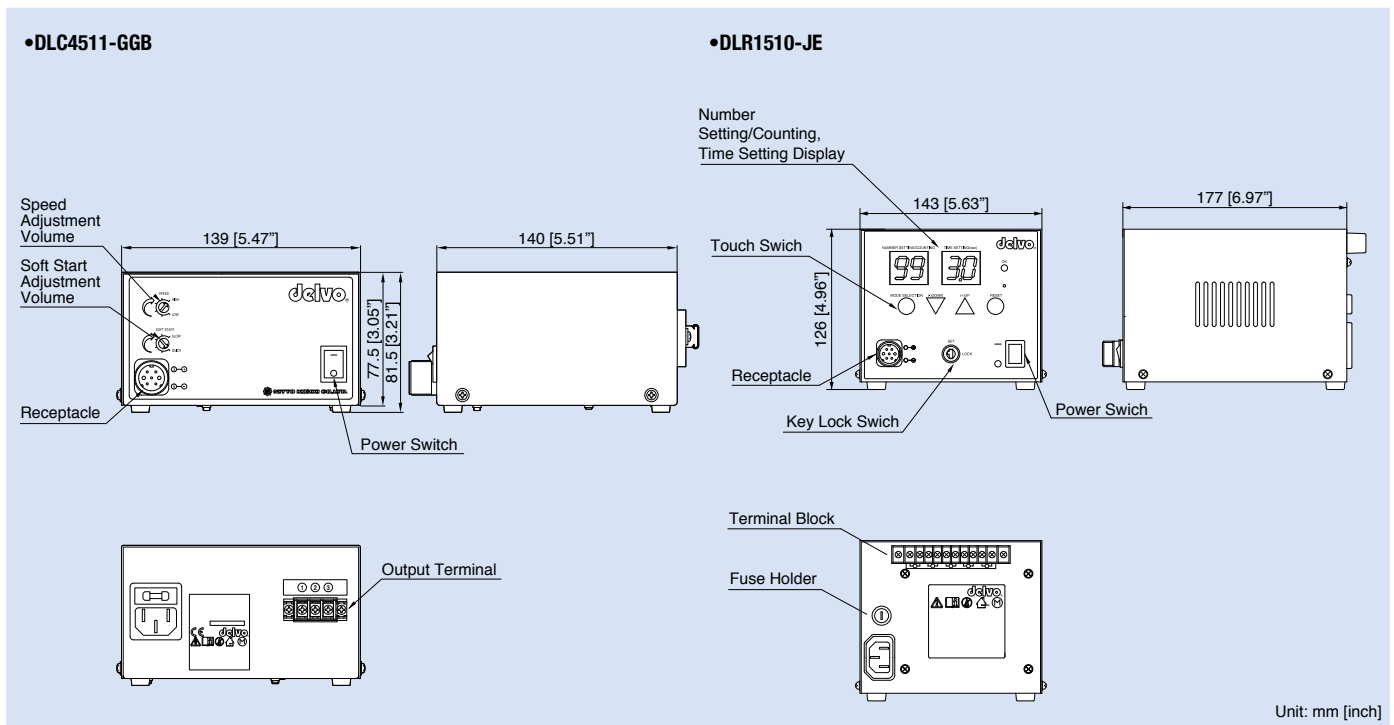

MEMO

A series of horizontal dotted lines for writing.

Transformerless (AC)
 Brush motor / Brushless motor
 Miniature screw / Precision screw / Machine screw
 1.0 - 3.5 mm



DLV7000/8000 Series Non-CE



Features

100 / 115 V AC Direct Transformerless Precision Miniature Screw Type

- A built-in controller model saves space and facilitates layout change
- High repetitive torque accuracy
- Available with lever type (DLV7000 series) for each screw alignment and push to start type (DLV8000 series) for rapid screw tightening
- The high-speed type (DLV7031/8031) available at 1200 min⁻¹ for improving work efficiency (100 V AC only)

Specifications

		Standard				High Speed			
Electric Screwdriver	Model	100 V AC Input	DLV7020-EMN	DLV7030-EMN	DLV8020-EMN	DLV8030-EMN	DLV7031-EMN	DLV8031-EMN	
		115 V AC Input	DLV7020-FME*1	DLV7030-FME*1	DLV8020-FME*1	DLV8030-FME*1			
	Starting Method		Lever Start		Push to Start		Lever Start	Push to Start	
	Torque Adjustment		Stepless						
	Torque	(Nm [lbf·in])	0.05 - 0.55 [0.4 - 4.9]	0.3 - 1.1 [2.7 - 9.7]	0.1 - 0.55 [0.9 - 4.9]	0.3 - 1.1 [2.7 - 8.9]	0.3 - 1.0 [2.7 - 8.9]		
	Free Speed	(min ⁻¹)	900	650	900	650	1200		
	Power Consumption	(W)	Approx. 25						Approx. 30
	Screw Size	Machine Screw	1.0 - 3.0	2.0 - 3.5	1.0 - 3.0	2.0 - 3.5	2.0 - 3.0		
		Tapping Screw	1.2 - 2.6	2.0 - 3.0	1.2 - 2.6	2.0 - 3.0	2.0 - 3.0		
	Mass	(g [lbs])	400 [0.88]		410 [0.90]		400 [0.88]	410 [0.90]	
Bit Type				Asia 	*1: These models are made to order.				
		unit: mm							

Standard Accessories

Model		DLV7020 / 8020	DLV7030 / 8030 / 7031 / 8031
Bit	No.0 × 2.5 × 44	1	-
	No.1 × 3 × 44	-	1
	No.1 × 4 × 44	1	-
	No.2 × 4 × 44	-	1
Spare Carbon Brush		1	

Torque Diagrams (for reference)

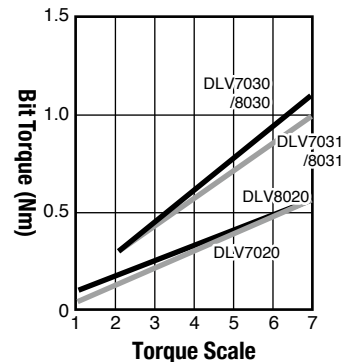

Optional Accessories



This minimizes tampering or accidental turning of the torque adjustment ring once the torque is set.

Torque Adjustment Ring Cover
 DLW5300 (TD00332)

External Dimensions

•DLV7020/7030/7031

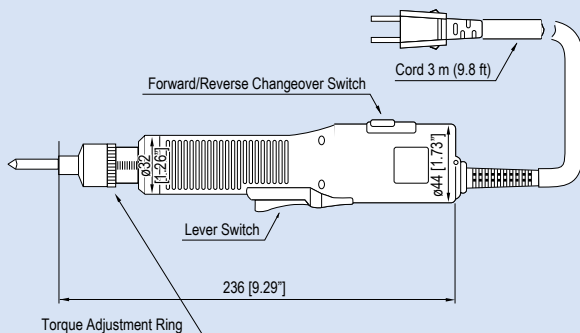

•DLV8020/8030/8031

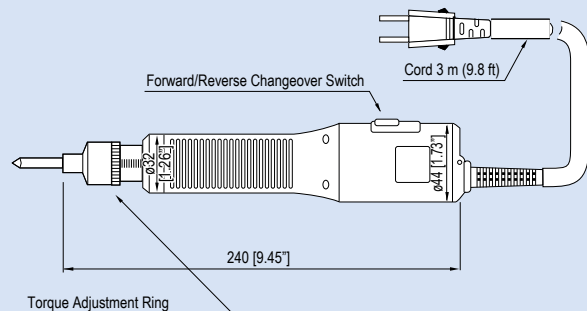

unit: mm [inch]

DLV7100/7200/8100/8200 Series Non-CE



Features

Long Time Selling, Reliable, and High Performance

- Transformerless space saving model built in automatic stop circuit
- Combination of unique clutch mechanism and automatic stop circuit maintains high repetitive torque accuracy
- The lever start type DLV7100 / 7200 series is suited for temporarily tightening screws and tightening screws set at angles
- The DLV8100 / 8200 series is push to start type for continuous screw tightening
- The high speed type DLV7200 / 8200 series enhances working efficiency
- The high torque type DLV7251 / 8150 / 8251 series is equipped with a grip, which is useful for tightening big screws like 6 mm machine screws

Specifications

Model	Bit Shank: Hex. 5 mm (0.2") Bit Shank: Hex. 6.35 mm (1/4")	Standard			High Speed			High Torque	Standard			High Torque	High Speed			High Torque	
		DLV7120-FJE	DLV7130-FJE	DLV7140-FJE	DLV7221-FJE	DLV7231-FJE	DLV7241-FJE	DLV7251-FKE	DLV8120-FJE	DLV8130-FJE	DLV8140-FJE	DLV8150-FJE	DLV8221-FJE	DLV8231-FJE	DLV8241-FJE	DLV8251-FKE	
Starting Method		Lever Start							Push to Start								
Input Voltage		115 V AC, 50/60 Hz															
Torque Adjustment		Stepless															
Torque	(Nm)	0.35 - 0.70	0.5 - 1.7	1.2 - 3.0	0.35 - 0.70	0.5 - 1.7	1.2 - 3.0	2.0 - 4.5	0.35 - 0.70	0.5 - 1.7	1.2 - 3.0	2.0 - 4.5	0.35 - 0.70	0.5 - 1.7	1.2 - 3.0	2.0 - 4.5	
	[lbf-in]	[3.10 - 6.20]	[4.4 - 15.1]	[10.6 - 26.6]	[3.10 - 6.20]	[4.4 - 15.1]	[10.6 - 26.6]	[17.7 - 39.8]	[3.10 - 6.20]	[4.4 - 15.1]	[10.6 - 26.6]	[17.7 - 39.8]	[3.10 - 6.20]	[4.4 - 15.1]	[10.6 - 26.6]	[17.7 - 39.8]	
Free Speed	(min ⁻¹)	900	900	600	1800	1800	1100	700	900	900	600	400	1800	1800	1100	700	
Power Consumption	(W)	Approx. 35				Approx. 45				Approx. 35				Approx. 45			
Screw Size	Machine Screw	2.6 - 3.0	2.6 - 4.0	3.5 - 5.0	2.6 - 3.0	2.6 - 4.0	3.5 - 5.0	4.5 - 6.0	2.6 - 3.0	2.6 - 4.0	3.5 - 5.0	4.5 - 6.0	2.6 - 3.0	2.6 - 4.0	3.5 - 5.0	4.5 - 6.0	
	Tapping Screw	2.6 - 3.0	2.3 - 3.5	3.5 - 4.0	2.6 - 3.0	2.3 - 3.5	3.0 - 4.0	4.5 - 5.0	2.6 - 3.0	2.3 - 3.5	3.5 - 4.0	4.5 - 5.0	2.6 - 3.0	2.3 - 3.5	3.0 - 4.0	4.0 - 5.0	
Mass	(g [lbs])	700 [1.54]				890 [1.96]				690 [1.52]				890 [1.96]			
Bit Type (mm)	For FJE				For FKE				Asia								
	Plug Shape																

* All models of FJE / FKE series are made to order.

Standard Accessories

Model	FJE	FKE except DLV7251 / 8150 / 8251-FKE	DLV7251 / 8150 / 8251-FKE
Bit			
No.1 x 6 x 70	1	-	-
No.1 x 7 x 75	-	1	-
No.2 x 6 x 70	1	-	-
No.2 x 7 x 75	-	1	1
No.3 x 7 x 50	-	-	1
Spare Carbon Brush	2		
Suspension Bail	1		

Torque Diagrams (for reference)

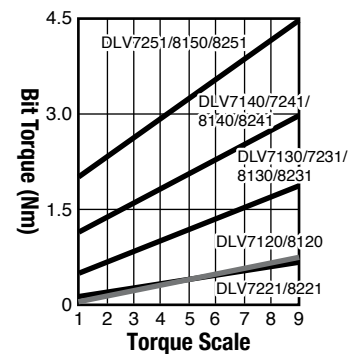

External Dimensions

•DLV7120/7130/7140/7221/7231/7241

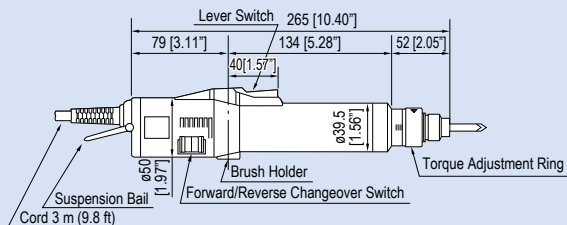

•DLV8120/8130/8140/8221/8231/8241

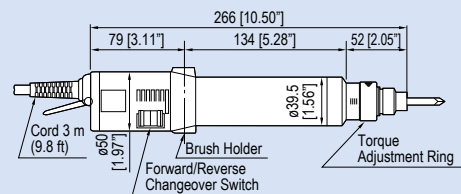

•DLV7251

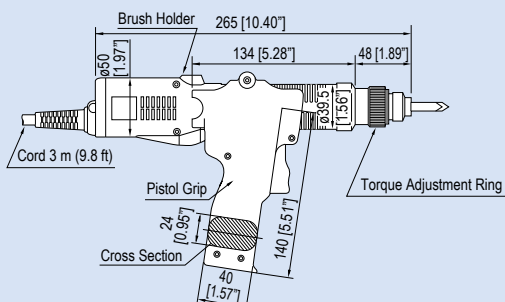

•DLV8150/8251

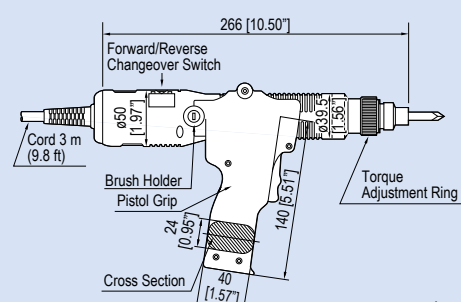

unit: mm [inch]

Transformerless (AC)
 Brush motor / Brushless motor
 Miniature screw / Precision screw / Machine screw
 2.6 - 6.0 mm



DLV7104/8104/8204 Series Non-CE



Features

The most popular models have been redesigned

- Equipped with bit grounding mechanism
- Long-life cam is utilized
- The clear plastic torque adjustment ring cover minimizes unintentional tampering of the preset torque
- The changeover switch enables operators to change forward/reverse rotation with a single hand
- The ergonomically designed grip can be held tightly to resist against tightening reaction force, resulting in reduced operator fatigue

Specifications

Model	Plug Shape: USA	DLV7124-MKE	DLV7134-MKE	DLV7144-MKE	DLV8124-MKE	DLV8134-MKE	DLV8144-MKE	DLV8154-MKE	DLV8224-MKE	DLV8234-MKE	DLV8244-MKE
	Plug Shape: UK	DLV7124-MKH	DLV7134-MKH	DLV7144-MKH	DLV8124-MKH	DLV8134-MKH	DLV8144-MKH	DLV8154-MKH	DLV8224-MKH	DLV8234-MKH	DLV8244-MKH
Starting Method	Lever Start						Push to Start				
Input Voltage	230 V AC, 50/60 Hz										
Torque Adjustment	Stepless										
Torque (Nm)	0.25 - 0.75	0.5 - 1.7	1.2 - 3.0	0.25 - 0.75	0.5 - 1.7	1.2 - 3.0	2.0 - 4.5	0.35 - 0.7	0.5 - 1.7	1.2 - 3.0	
(lbf-in)	[2.2 - 6.6]	[4.4 - 15.1]	[10.6 - 26.6]	[2.2 - 6.6]	[4.4 - 15.1]	[10.6 - 26.6]	[17.7 - 39.8]	[3.1 - 6.2]	[4.4 - 15.1]	[10.6 - 26.6]	
Free Speed (min ⁻¹)	900		600	900		600	400	2000	1800	1100	
Power Consumption (W)	35						45				
Screw Size (mm)	Machine Screw	2.6 - 3.0	2.6 - 4.0	3.5 - 5.0	2.6 - 3.0	2.6 - 4.0	3.5 - 5.0	4.5 - 6.0	2.6 - 3.0	2.6 - 4.0	3.5 - 5.0
	Tapping Screw	2.3 - 3.0	2.3 - 3.5	3.0 - 4.0	2.3 - 3.0	2.3 - 3.5	3.0 - 4.0	4.5 - 5.0	2.3 - 3.0	2.3 - 3.5	3.0 - 4.0
Mass (g [lbs])	720 [1.59]			710 [1.57]			910 [2.01]	710 [1.57]			

Bit Type	Plug Shape	For MKE		For MKH	
		USA	UK	USA	UK
<p>unit: mm</p>					

Please contact us for 5 mm bit type.

Standard Accessories

Model	MKE/MKH	8154-MKE/MKH	
Bit	No.1 x 7 x 75	1	-
	No.2 x 7 x 75	1	1
	No.3 x 7 x 50	-	1
Spare Carbon Brush	2		
Suspension Bail	1		

Torque Diagrams (for reference)

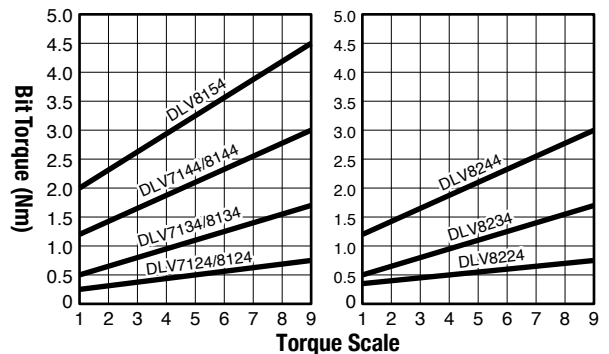

External Dimensions

•DLV7124 / 7134 / 7144

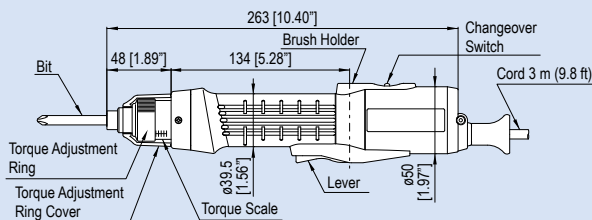

•DLV8154

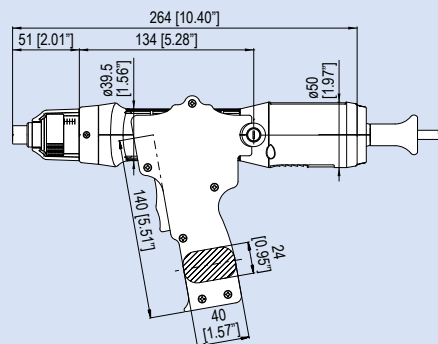

•DLV8124 / 8134 / 8144 / 8224 / 8234 / 8244

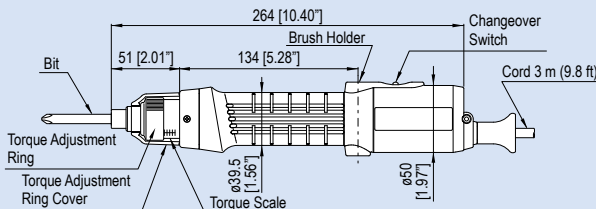

unit: mm [inch]

Screw Fastening Counter Series

Prevents human error with various functions. * Special models available on request

The error is detected based on the set tightening time.

Self adjustable timer function

The optimum value of screw tightening time is set from the actual screw tightening.



The best time is X seconds per screw



Count Correction Function

Does not count when error is detected.

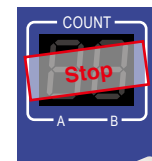
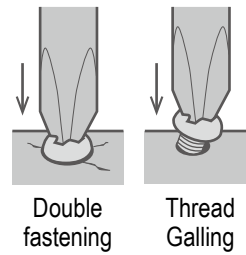

Error !



Human error prevention

Link Connection Function

Multiple screwdrivers can be linked. The other screwdrivers will be in standby state.

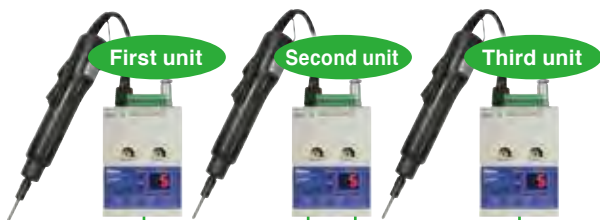

Link Connection

Link Connection

Count Return Function

The remaining number of screw tightening is returned when the rotation is reversed.

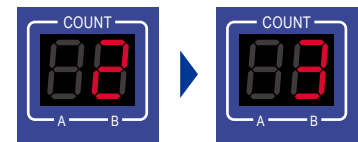
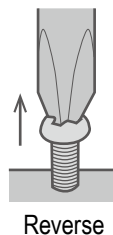

Return one count

Driver Lock Function

Unnecessary screwdrivers are locked in conjunction with the workpiece sensor.

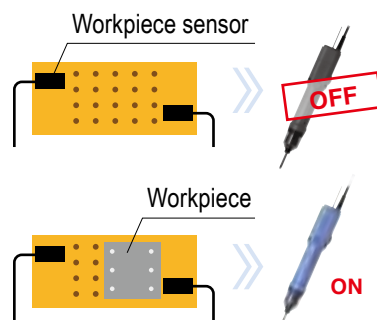

Lock when workpiece is not in place !



Screw Fastening Counter

DLR5640-WN

- Functions of the controller and counter are integrated into a single unit.
- Equipped with Linear Start Function that gradually increases the rotation speed at start.
- Universal power input for use anywhere in the world.



Front and Rear Panels

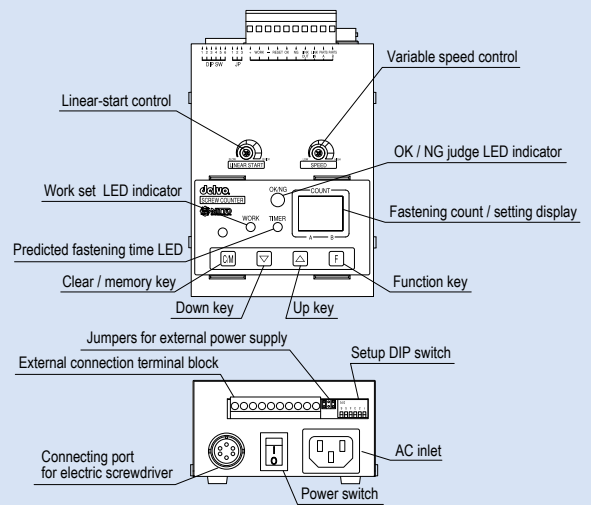

DLR5040A-WE

- Compact and lightweight model.
- A wide range of SPC screwdriver types are available.

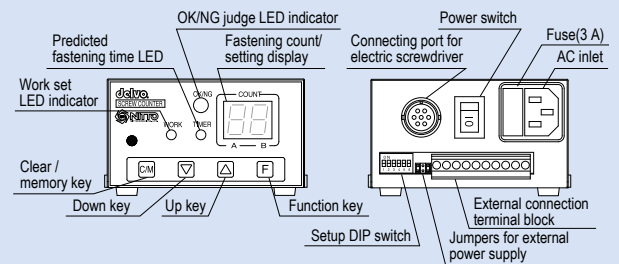

DLR5340-WE

- Three dedicated screwdrivers can be connected.
- Eight kinds of screw fastening conditions can be stored in internal memory.

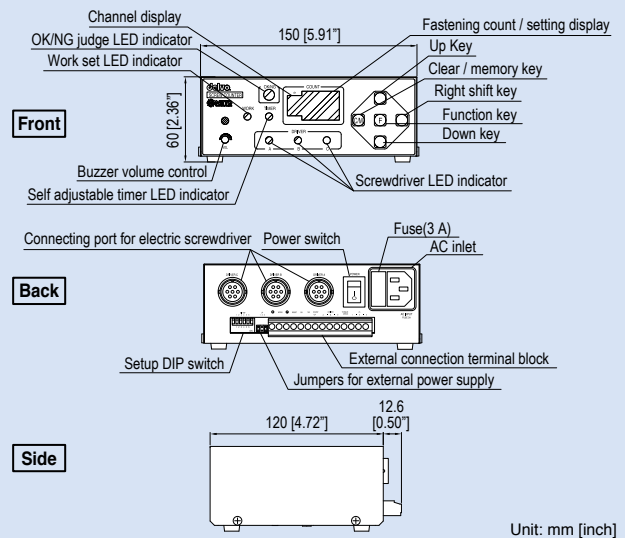

Unit: mm [inch]

Function List

	Self adjusting timer function	Count correct function	Link connection function	Count return function	Driver lock function	Number of connecting ports
DLR5640-WN	•	•	•	•	•	1
DLR5040A-WE	•	•	•	•	•	1
DLR5340-WE	•	•		•	•	3



Features

The self-adjustable timer function automatically assesses the time required to complete fastening each screw and reflects it on the judging time setting

- Ideally suited for the assembly lines of vehicles and electrical equipment requiring reliable screw fastening
 - The controller receives signals from electric screwdrivers to provide highly reliable screw fastening control
 - Functions of the controller and counter are integrated into a single unit
 - Count Return Function: When a screw is loosened, a reverse signal output from the electric screwdriver reverses the count by one
 - The self-adjustable timer function automatically assesses the time required to complete tightening each screw and reflects it on the judging time setting
 - The Count Correction Function does not count elevated screws or double fastening as fastening errors
 - External Count Function: To be available to various assembling jobs, the DLR5640 enables counting of two kinds of parts (up to 9 counts each) in addition to the screw tightening counting. These kinds of counting can be used together.
- Link Connection Function: You can build up a simple sequential screw tightening system by connecting the DLR5640 screw tightening counters in series without using any external controller such as a programmable controller
 - Driver Lock Function prevents unexpected start of screwdrivers
 - Desktop or wall-hung installation is available
 - Input voltage range from 100 V AC to 240 V AC is acceptable in any part of the world

Specifications

Model	DLR5640-WN
Count	1 - 99
Counting Method	Count-up / Count-down
Count Correction Function	Count normal fastening only
Self Adjustable Timer Setting	0.01 to 0.99 sec.
Work Detection Function	Yes (1 terminal) / No
External Count Input	2 terminals (PARTS A / PARTS B)
Work Installation Timer Setting	0 to 9.5 sec.
OK Output Timer Setting	0 to 9.5 sec.
NG Alarm	ON(1) / ON(2) / OFF
OK Buzzer	ON(1) / ON(2) / ON(3) / OFF
Count Return Function	ON / OFF
NG Judge Timing	WORK SET / DRIVER ON
Automatic / Manual OK Judge	AUTO / MANUAL
Screwdriver Lock Function	ON / OFF
Multiple Link	Up to 10 counters can be connected.
External Inputs on Terminal Block	SENSOR / RESET / LINK-IN / PARTS A / PARTS B
External Outputs on Terminal Block	OK / NG / LINK-OUT
Parameter Memory	Parameters stored in internal nonvolatile memory
Screwdriver Control	SPEED / LINEAR START
Input Voltage	100 - 240 V AC, 50/60 Hz
Screwdriver Power Supply	33 V DC, 1.5 A
External Dimensions (mm [inch])	W101 x D140 x H57 [W3.98" x D5.51" x H2.24"]
Mass (g [lbs])	800 [1.76]
Accessories	2 m Power cord with USA plug Suspension bail (2 pcs.)

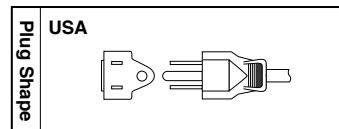

Example of use together with a sensor available in the market



The example of installation

LINK Function (Common to DLR5040A & DLR5640)

When counters are connected and activated in the screw fastening sequence as shown below, all screwdrivers are on standby except the first one in the sequence. Only when the first screw fastening is finished, can the next screwdriver change from standby to ready. When the last fastening in the sequence is finished, the first screwdriver is once again ready and the sequence can be repeated again.
N.B. Up to 10 screwdriver/counter sets can be connected to the LINK.

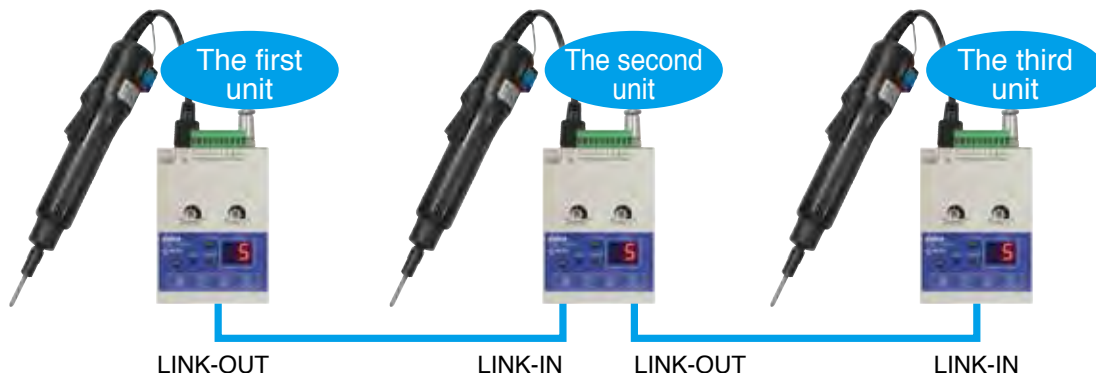

Screwdrivers designed for DLR5640-WN Non-CE



DLV7410A/7410HA/7420A-SPC



DLV7321/7331-SPC



DLR5640-WN

Specifications

Model	DLV7410A-SPC	DLV7410HA-SPC	DLV7420A-SPC	DLV7321-SPC	DLV7331-SPC
Starting Method	Lever Start				
Torque Adjustment	Stepless				
Torque (Nm [lbf-in])	0.02 - 0.2 [0.2 - 1.8]		0.15 - 0.4 [1.3 - 3.5]	0.1 - 0.5 [1.9 - 4.4]	0.3 - 1.2 [2.7 - 10.6]
Free Speed (min ⁻¹)	500 - 750	700 - 1000	450 - 600	300 - 1000	200 - 700
Power Consumption (W)	Approx. 10			Approx. 35	
Screw Size (mm)	Machine Screw	1.0 - 2.3	1.6 - 2.6	1.0 - 3.0	2.0 - 3.5
	Tapping Screw	1.0 - 2.0	1.4 - 2.3	1.2 - 2.6	2.0 - 3.0
Electrostatic Countermeasure	Complied with EN100015-1				
Mass (g [lbs])	230 [0.51]			350 [0.77]	
Cord Length (m)	1.5 (with connector)				
Grounding Bit Feature	Equipped as standard				

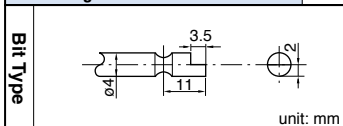

Combinations with Electric Screwdrivers

Screwdriver Model	Connection	Remarks
DLV7410A / 7410HA / 7420A-SPC	The cord comes with screwdriver	Screwdriver for the screw fastening counter only
DLV7321 / 7331-SPC	Direct connection to power source	
DLV7410A / 7410HA / 7420A / 7419A / 7419HA / 7429A-BMN	Optional conversion cord (TD02925 DLW9072)	General-purpose screwdriver *1

*1: The Count Return Function is not available.

Optional Accessories



DLW9072(TD02925)



Torque Adjustment Ring Cover
(DLW5700: DLV7400A-SPC
DLW5300: DLV7300-SPC)

This minimizes tampering or accidental turning of the torque adjustment ring once the torque is set.



Features

For prevention of human fastening errors and enhanced fastening management accuracy

- Ideally suited for the assembly lines of vehicles and electrical equipment requiring reliable screw fastening
- The controller receives signals from electric screwdrivers to provide highly reliable screw fastening control
- Count Return Function: When a screw is loosened, a reverse signal output from the electric screwdriver reverses the count by one
- The Count Correction Function does not count elevated screws or double fastening
- Input voltage range from 100 to 240 V AC is acceptable in any part of the world

(The screwdrivers to be used in combination with the counter require input power supplies that are written on the respective nameplate)

- Link Connection Function: You can build up a simple sequential screw tightening system by connecting the DLR5040A-WE screw tightening counters in series without using any external controller such as a programmable controller
- Driver Lock Function prevents unexpected start of screwdrivers
- Compact and Lightweight (Compared with our conventional models decreased by 30 % in volume and by 38 % in mass)
- SPC type screwdrivers for DLR5040A-WE are designed on the basis of established transformerless screwdrivers

Specifications

Model	DLR5040A-WE
Count	1 - 99
Counting Method	Count-up / Count-down
Count Correction Function	Count normal fastening only
Self Adjustable Timer Setting	0.01 to 0.99 sec.
Work Detection Function	Yes (1 terminal) / No
External Count Input	2 terminals (PARTS A / PARTS B)
Work Installation Timer Setting	0 to 9.5 sec.
OK Output Timer Setting	0 to 9.5 sec.
NG Alarm	ON(1) / ON(2) / OFF
OK Buzzer	ON(1) / ON(2) / ON(3) / OFF
Count Return Function	ON / OFF
NG Judge Timing	WORK SET / DRIVER ON
Automatic / Manual OK Judge	AUTO / MANUAL
Screwdriver Lock Function	ON / OFF
Multiple Link	Up to 10 counters can be connected.
External Inputs on Terminal Block	SENSOR / RESET / LINK-IN / PARTS A / PARTS B
External Outputs on Terminal Block	OK / NG / LINK-OUT
Parameter Memory	Parameters stored in internal nonvolatile memory
Input Voltage	100 - 240 V AC, 50/60 Hz
External Dimensions (mm [inch])	W100 x D120 x H60 [W3.94" x D4.72" x H2.36"]
Mass (g [lbs])	470 [1.04]

Accessory: 2 m cord with UL three-prong plug. This product is for use outside Japan.

LINK Function

When counters are connected and activated in the screw fastening sequence as shown below, all screwdrivers are on standby except the first one in the sequence. Only when the first screw fastening is finished, can the next screwdriver change from standby to ready. When the last fastening in the sequence is finished, the first screwdriver is once again ready and the sequence can be repeated again.

N.B. Up to 10 screwdriver/counter sets can be connected to the LINK.



Example of use together with a sensor available in the market

DLR5340-WE Non-CE



Features

Up to three sets screwdrivers can be connected to one counter

- Up to eight kinds of screw fastening conditions can be stored in internal memory for a wide variety of assembly work
- Count-up signal outputs
- Space saving
- The Count Correction Function does not count elevated screws or double fastening as fastening errors
- Count Return Function: When a screw is loosened, a reverse signal output from the electric screwdriver reverses the count by one

Specifications

Model	DLR5340-WE
Count	0 - 99
Counting Method	Count-up / Count-down
Count Correction Function	Count normal fastening only
Self Adjustable Timer Setting	0.01 to 2.50 sec.
Work Detection Function	Yes (1 terminal) / No
Work Installation Timer Setting	0 to 9.5 sec.
OK Output Timer Setting	0 to 9.5 sec.
NG Alarm	ON(1) / ON(2) / OFF
OK Buzzer	ON(1) / ON(2) / ON(3) / ON(4) / ON(5) / OFF
Count Return Function	ON / OFF
Screwdriver Lock Function	ON / OFF
Screwdriver Cord Connection	Single cord connection (Signal and power lines)
External Inputs on Terminal Block	SENSOR / RESET / TORQUE CHECK / ch1/2/3
External Outputs on Terminal Block	OK / NG / COUNT-UP / DRIVER A/B/C
Input Voltage	100 - 240 V AC, 50/60 Hz
External Dimensions (mm [inch])	W150 x D120 x H60 [W5.91" x D4.72" x H2.36"]
Mass (g [lbs])	620 [1.37]

Accessory: 2 m cord with UL three-prong plug. This product is for use outside Japan.

Dedicated Screwdrivers for DLR5040A-WE and DLR5340-WE Non-CE

Small



Big

Specifications

		Miniature Screw (1.0 - 3.5 mm)					
Model	Lever Start	DLV7020-SPC	DLV7030-SPC	DLV7031-SPC	-	-	-
	Push to Start	-	-	-	DLV8020-SPC	DLV8030-SPC	DLV8031-SPC
Input Voltage		100 V AC, 50/60 Hz					
Torque Adjustment		Stepless					
Torque (Nm [lbf-in])		0.05 - 0.55 [0.4 - 4.9]	0.30 - 1.10 [2.7 - 9.7]	0.30 - 1.00 [2.7 - 8.9]	0.10 - 0.55 [0.9 - 4.9]	0.30 - 1.10 [2.7 - 9.7]	0.30 - 1.00 [2.7 - 9.9]
Free Speed (min ⁻¹)		900	650	1200	900	650	1200
Power Consumption (W)		Approx. 25		Approx. 30	Approx. 25		Approx. 30
Screw Size (mm)	Machine Screw	1.0 - 3.0	2.0 - 3.5	2.0 - 3.0	1.0 - 3.0	2.0 - 3.5	2.0 - 3.0
	Tapping Screw	1.2 - 2.6	2.0 - 3.0		1.2 - 2.6	2.0 - 3.0	
Bit Type		A					
Mass (g [lbs])		380 [0.84]			390 [0.86]		
Cord Length (m)		3 (with connector)					
Bit Grounding		Equipped as standard					

		Machine Screw (2.6 - 8.0 mm)					
Model	Lever Start	DLV7120-SPC	DLV7130-SPC	DLV7140-SPC	DLV7231-SPC	DLV7241-SPC	
	Push to Start	DLV8120-SPC	DLV8130-SPC	DLV8140-SPC	DLV8231-SPC	DLV8241-SPC	
Input Voltage		100 V AC, 50/60 Hz *1					
Torque Adjustment		Stepless					
Torque (Nm [lbf-in])		0.35 - 0.70 [3.10 - 6.20]	0.50 - 1.70 [4.4 - 15.1]	1.20 - 3.00 [10.6 - 26.6]	0.50 - 1.70 [4.4 - 15.1]	1.20 - 3.00 [10.6 - 26.6]	
Free Speed (min ⁻¹)		1000		700	2000		1200
Power Consumption (W)		35			45		
Screw Size (mm)	Machine Screw	2.6 - 3.0	2.6 - 4.0	3.5 - 5.0	2.6 - 4.0	3.5 - 5.0	
	Tapping Screw	2.3 - 3.0	2.5 - 3.5	3.0 - 4.0	2.5 - 3.5	3.0 - 4.0	
Bit Type		B *2					
Mass (g [lbs])		710 [1.57] (7100series) / 670 [1.48] (8100series)			710 [1.57] (7200series) / 670 [1.48] (8200series)		
Cord Length (m)		3 (with connector)					
Bit Grounding		Equipped as standard					

		Machine Screw (2.6 - 8.0 mm)	
Model	Lever Start	-	DLV7251-SPC
	Push to Start	DLV8150-SPC	DLV8251-SPC
Input Voltage		100 V AC, 50/60 Hz *1	
Torque Adjustment		Stepless	
Torque (Nm [lbf-in])		2.0 - 4.5 [17.7 - 39.8]	
Free Speed (min ⁻¹)		450	700
Power Consumption (W)		45	
Screw Size (mm)	Machine Screw	4.5 - 6.0	
	Tapping Screw	4.0 - 5.0	
Bit Type		C	
Mass (g [lbs])		810 [1.79]	
Cord Length (m)		3 (with connector)	
Bit Grounding		Equipped as standard	

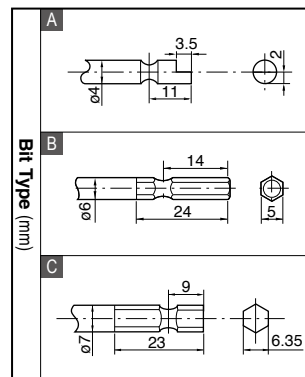

		Machine Screw (2.6 - 8.0 mm)					
Model	Lever Start	DLV30A06L-SPC	DLV30A12L-SPC	DLV30A20L-SPC	DLV45A06L-SPC	DLV45A12L-SPC	DLV70A06L-SPC
	Push to Start	DLV30A06P-SPC	DLV30A12P-SPC	DLV30A20P-SPC	DLV45A06P-SPC	DLV45A12P-SPC	DLV70A06P-SPC
Input Voltage		100 V AC, 50/60 Hz *1					
Torque Adjustment		Stepless					
Torque (Nm [lbf-in])		0.4 - 1.6 / 1.2 - 3.0 [3.5 - 14.2 / 10.6 - 26.6]			2.0 - 4.5 [17.7 - 39.8]		3.8 - 7.0 [33.6 - 62.0]
Free Speed (min ⁻¹)		650	1200	2000	650	1200	650
Power Consumption (W)		45					
Screw Size (mm)	Machine Screw	2.6 - 5.0			4.5 - 6.0		5.0 - 8.0
	Tapping Screw	2.5 - 4.0			4.0 - 5.0		4.5 - 6.0
Bit Type		B *2				C	
Mass (g [lbs])		700 [1.54]			870 [1.92] with pistol grip		
Cord Length (m)		3 (with connector)					
Bit Grounding		Equipped as standard					

*1: Please contact us for other voltage availabilities. *2: Please contact us for 6.35 mm bit type.

Optional Accessories



Torque Adjustment Ring Cover
DLW5200: DLV7100/7200/8100/8200-SPC
DLW5300: DLV7000/8000-SPC

- This minimizes tampering or accidental turning of the torque adjustment ring once the torque is set.
- Flanged coupling DLW9011 can not be mounted on SPC type



Pistol Grip
DLW2300: DLV7100/7200/
8100/8200/30/45/70-SPC

- Suitable for horizontal operation



TD04061 SPC cord for commercial power source (optional)

- Dedicated screwdrivers can be directly plugged in commercial power source.

Transformerless (AC)
 Brush motor **Brushless motor**
 Miniature screw Precision screw **Machine screw**
2.6 - 8.0 mm



Delvo Brushless Type

A Series (For Automation) Model DLV30A/45A/70A Non-CE



The Vacuum Pickup is optional.

Features

For automatic assembly robot

- Three series of screwdrivers can be mounted on the XY robot
- Automatic screw tightening achieves a labor-saving or unattended process
- Long-life brushless motors are incorporated in the electric screwdrivers
- Standard coupling, flange coupling, and left-hand thread coupling are available for installation
- The electric screwdriver generates the torque-up signal
- The screwdrivers can be connected to a sequencer to control starting, forward rotation, and reverse rotation
- An electrical noise preventive measure is employed to avoid malfunction. Each input/output signal is insulated from a screwdriver's internal circuit by a photocoupler.

Specifications

		Low Speed	Standard	High Speed	Low Speed	Standard	Low Speed
Model : Bit	Standard coupling	DLV30A06A-N(AA) : J	DLV30A12A-N(AA) : J	DLV30A20A-N(AA) : J	DLV45A06A-N(AA) : K	DLV45A12A-N(AA) : K	DLV70A06A-N(AA) : K
	Coupling with flange	DLV30A06A-F(AA) : J	DLV30A12A-F(AA) : J	DLV30A20A-F(AA) : J	DLV45A06A-F(AA) : K	DLV45A12A-F(AA) : K	DLV70A06A-F(AA) : K
	Coupling with M41 screw	DLV30A06A-M(AA) : J	DLV30A12A-M(AA) : J	DLV30A20A-M(AA) : J	DLV45A06A-M(AA) : K	DLV45A12A-M(AA) : K	DLV70A06A-M(AA) : K
Input Voltage		100 V AC, 50/60 Hz					
Torque (Nm [lbf-in])	Low Torque Spring*1	0.4 - 1.6 [3.5 - 14.2]			2.0 - 4.5 [17.7 - 39.8]		3.8 - 7.0 [33.6 - 62.0]
	High Torque Spring*2	1.2 - 3.0 [10.6 - 26.6]					
Free Speed (min ⁻¹)		650	1200	2000	650	1200	650
Screw Size (mm)	Machine Screw	2.6 - 5.0			4.5 - 6.0		5.0 - 8.0
	Tapping Screw	2.5 - 4.0			4.0 - 5.0		4.5 - 6.0
Mass (g [lbs])	Standard coupling	700 [1.54]			780 [1.72]		
	Coupling with flange	760 [1.68]			840 [1.85]		
	Coupling with M41 screw	740 [1.63]			820 [1.81]		
Power Consumption (W)		45					
Starting Method		External input signal					
Input signal		Start signal / Forward signal / Reverse signal (5 - 24 V DC)					
Output signal		Torque-up signal (Voltage under 30 V DC and current 20 mA)					
Standard Accessories		• Bit NK31 × 2 × 6 × 70: 1 pc. • Low torque spring: 1 pc.			• Bit NK35 × 2 × 7 × 75: 1 pc.		
Bit Type (mm)		*3					
		*1: Standard Accessory *2: Built-in *3: DLV30A is available upon request for use with 6.35 mm hex. shank bits.					

Optional Accessories

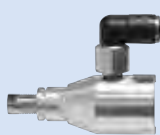

Vacuum Pickup
DLP7400 (M3/M4 screws)
DLP7400 for high torque (M5/M6 screws)



Vacuum Pump
DLP2530/2570

Part No. TD07285
Part No. TD07286

* Please see page 39 for details.

Torque Diagrams (for reference)

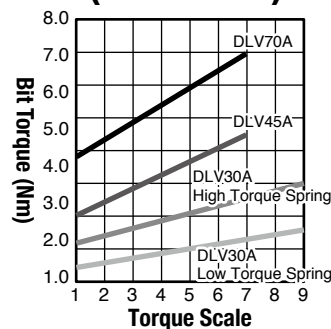

Screwdriver Cable Breakdown List

Color	Details
Green	Power input
Yellow	Power input
Blue	Bit earth
White	Input signal common (Vcc)
Black	Start signal input
Orange	Forward signal input
Gray	Reverse signal input

Power input voltage: 100 V AC

Output Signal Cable

Color	Details
White	Torque-up signal output
Black	Ground

Power Input/Output Signal Schematic Diagram

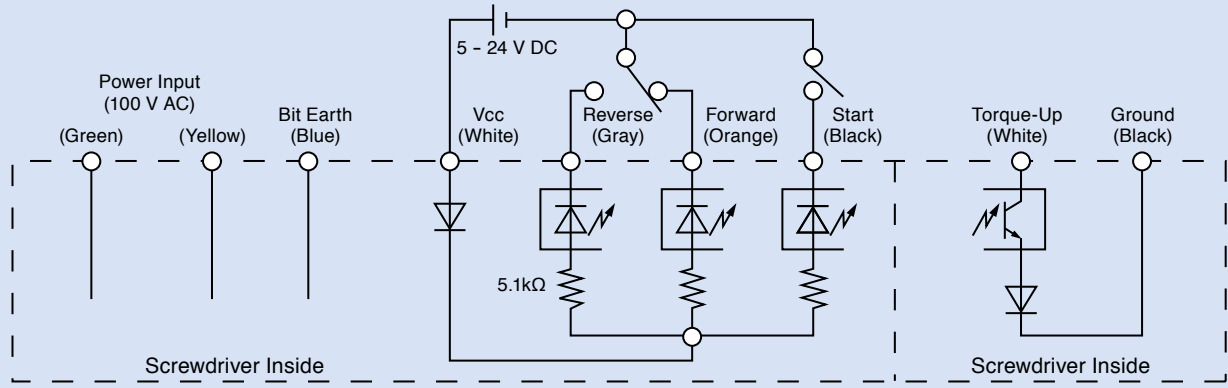

⚠ Caution

- Each input/output signal is insulated from a screwdriver's internal circuit.
- Input signal rated range: Use in the range of voltage between 5 – 24 V DC (current 0.5 – 5 mA DC)
- Torque-up signal output maximum rating: Use in the range of voltage under 30 V DC and current 20 mA DC.

Operation Timing Chart

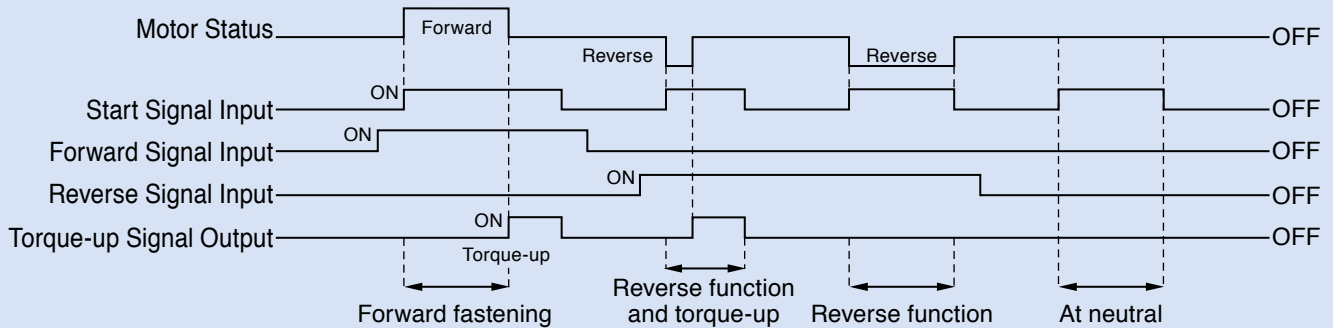

External Dimensions

•DLV30A□ A-N

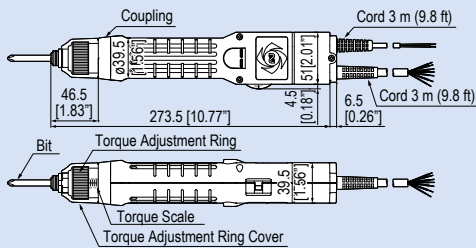

•DLV45A□ A-N/ 70A06A-N

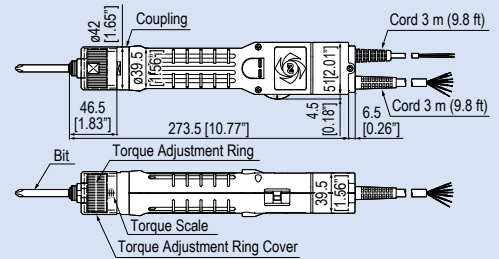

•DLV30A□ A-F

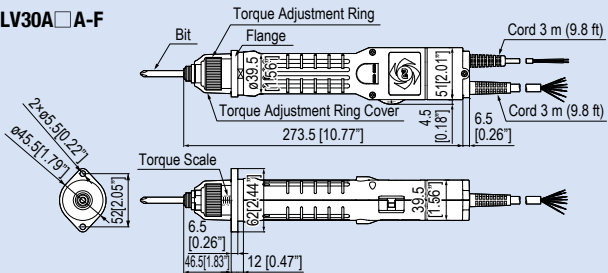

•DLV45A□ A-F/ 70A06A-F

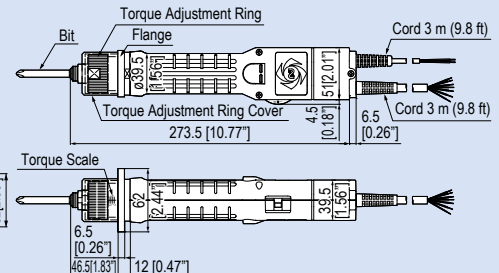

•DLV30A□ A-M

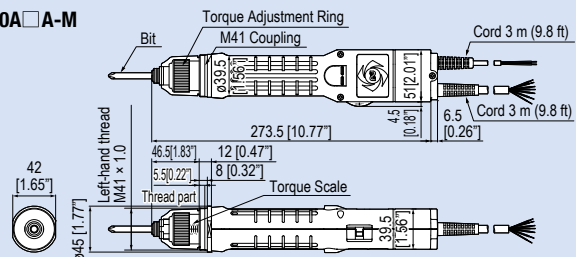

•DLV45A□ A-M/ 70A-M

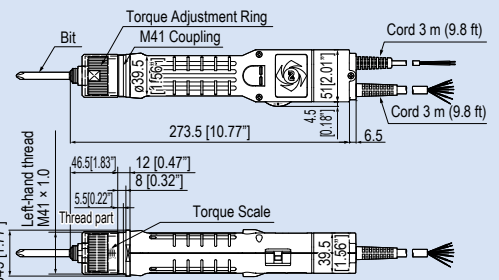

•DLP7400

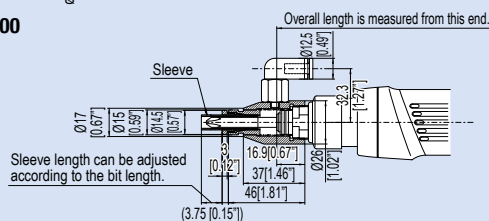

unit: mm [inch]



Features

Maintaining high assembly quality with ease

- Measured data is stored even after the power is turned off, preventing any data loss
- Energy saving type with AUTO POWER OFF function (Power is automatically turned off when left unused for 10 minutes)
- A program designed for uploading the data stored in the "delvo" torque checkers to a computer is available to download free from the NITTO KOHKI website:

www.nitto-kohki.co.jp/e/prd/e-dl/delvo.html



Click

Specifications

Model	DLT1173A	DLT1673A	DLT1973A
Measurement Range (Nm[lbf-in])	0.015 - 1.500 [0.13 - 13.3]	0.15 - 10.00 [13.5 - 88.5]	4.00 - 12.00 [35.4 - 106.2]
Calibration Precision	Within ± 0.5% (Full Scale) For 0.2 Nm [2 lbf-in] or less ± 1 digit	Within ± 0.5% (Full Scale) For 2 Nm [20 lbf-in] or less ± 1 digit	Within ± 0.5% (Full Scale)
Display	4-digit digital display (Single-line) Data sampling: 1000 times/sec. Display rate: 12 times/sec.		
Measuring Unit	kgf • cm, Nm, lbf • in (selectable)		
Data Memory	800 pieces of data		
Measuring Direction	CW and CCW		
Measuring Mode	3 modes: PD-TR-PP		
Auto Power Off	Power off if left untouched for 10 minutes		
External Output	As per USB output		Mitsutoyo Digimatic
Analog Output	Approx. 1.5 V max.	Approx. 1.0 V max.	Approx. 1.1 V max.
	No zero offset; identical waveforms produced in PP, PD, and TR modes		
Continuous Operation Time	20 hours		
External Dimensions (mm)	W160 × D110 × H47 [W6.3" × D4.33" × H1.85"]		W200 × D112 × H48.5 [W7.9" × D4.41" × H1.89"]
Mass (g [lbs])	1100 [2.43]		1400 [3.09]
Rechargeable Battery	Nickel metal hydride battery		
Charger Type	DLE1833A		
Input Voltage for Charger	100 - 240 V AC, 50/60 Hz		
Charging Time	4 hours		
Standard Accessories	• Screw Joint (DLW4430)	• Bit Joint (DLW4360) • Spring for Joint (DLW4660)	• Soft Joint (DLW4000)

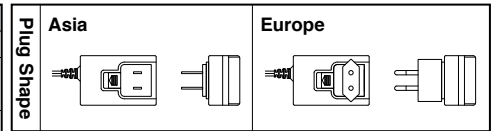

Selection of Torque Checker

DLT1173A	DLT1673A	DLT1973A
DLV3300*2	DLV7100/7200/	DLV45A/70A
DLV5700	8100/8200	DLV45S/70S
DLV5800	DLV7500/8500	DLV45A/70A
DLV7300	DLV3100*3	(automation)
DLV7000/8000	DLV30A/45A	
DLV7400A	DLV30S/45S	
DLV02/12	DLV16	
DLV04C/10C	DLV7104/8104/8204	
	DLV30A/45A	
	(automation)	

*2: A reversible screwdriver is required to loosen the measuring joint.

*3: A reversible screwdriver is required to loosen the measuring joint. Screw joint is required.

Optional Accessories

	Model	Part No.	Shape	Torque Range	DLT1173A	DLT1673A	DLT1973A
Bit Joint	DLW4330	TD03305	OD 4 mm [0.16"] type	0.015 - 0.25 Nm [0.13 - 2.2 lbf-in]	○	—	—
	DLW4340	TD03306	OD 4 mm [0.16"] type	0.15 - 1.5 Nm [1.3 - 13.3 lbf-in]	○	○	—
	DLW4350	TD03307	Hex 5 [0.2"] and Hex 6.35 [1/4"] types	0.15 - 1.5 Nm [1.3 - 13.3 lbf-in]	○	○	—
	DLW4360	TD03308	Hex 5 [0.2"] and Hex 6.35 [1/4"] types	0.15 - 6.5 Nm [1.3 - 57.5 lbf-in]	—	◎	—
Screw Joint	DLW4430	TD03309	screw type (Bit size No.2)	0.15 - 1.5 Nm [1.3 - 13.3 lbf-in]	◎	○	—
	DLW4530*1	TD03310	screw type (Bit size No.2)	0.15 - 5 Nm [1.3 - 44.3 lbf-in]	—	○	—
Soft Joint	DLW4000	TD04123	Hex 13 [0.51"] type	4.0 - 12.0 Nm [35.4 - 106.2 lbf-in]	—	○	◎
Hard Joint	DLW4040	TD04124	(Hex. head bolt)		—	—	○
Spring	DLW4660	TV03826	Spring for DLW4340, 4350, 4430		○	◎	—

*1 DLW4530 must be used at 5 Nm [44.3 lbf-in] or less.

◎: Standard accessories ○: Available as option —: Unsupported

Bit Joint



Screw Joint



Soft Joint



Hard Joint



Spring



External Dimensions

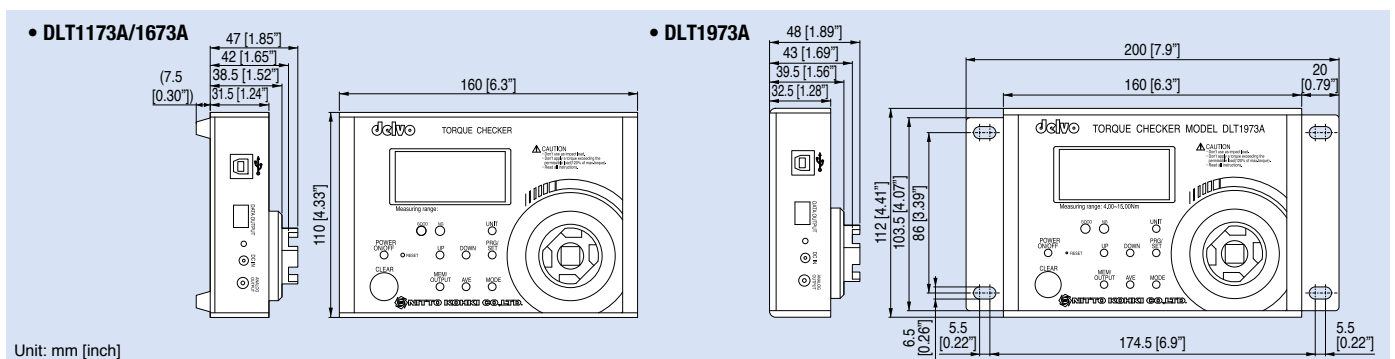

NK BIT

■ For DLV7400A, 5700, 5800, 7300, 7000, 8000, 3300 series

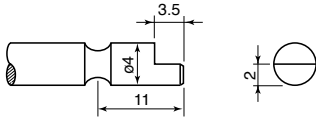

■ For DLV7100, 7200, 8100, 8200, 3100, A(DLV30A) series

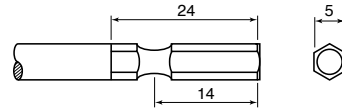

OD 4 mm Shank

Unit: mm

Model	Part No.	Size		Dimensions
		No. x d	x L	
Phillips NK4D	TD20009	00	2 44	
	TD20010		64	
	TD20021	0	1.8 44	
	TD20022		64	
	TD20029	2.5 44		
	TD20030		64	
	TD20037	1	3 44	
	TD20038		64	
	TD20039	4 44		
	TD20040		64	
	TD20047	2	4 44	
	TD20048		64	
TD20050	3 6 44			
Model	Part No.	W x T x L	Dimensions	
Plain Slot NK4DM	TD20051	2 0.3 44		
	TD20052	2.5 0.3 44		
	TD20053	3 0.4 44		
	TD20054	4 0.5 44		
	TD20055	5 0.65 44		
Model	Part No.	H x L	Dimensions	
Hexagon Head NK4DX	TD20056	1.5 44		
	TD20057	2 44		
	TD20058	2.5 44		
	TD20059	3 44		
	TD20060	4 44		
Model	Part No.	H x d x L	Dimensions	
Hex Socket NK4DB	TD20064	4 6 44		
	TD20065	4.5 7 44		
	TD20066	5 7 44		
	TD20067	5.5 8 44		

OD 5 mm Hex. Shank

Unit: mm

Model	Part No.	Size		Dimensions
		No. x d	x L	
Phillips NK31	TD20193	1	4 70	
	TD20194		100	
	TD20196		70	
	TD20197	5 100		
	TD20200	6 70		
	TD20201	100		
	TD20210	2	5 70	
	TD20211		100	
	TD20214		70	
	TD20215	6 70		
TD20224	1	70		
TD20225		100		
TD20232		70		
TD20233		100		
TD20235	2 150			
Model	Part No.	H x d x L	Dimensions	
Hexagon Head NK31X	TD20254	2 4 70		
	TD20256	2.5 70		
	TD20258	3 70		
	TD20260	4 70		
	TD20262	5 70		
Model	Part No.	H x D x d x L	Dimensions	
Hex Socket NK31B	TD20272	5.5 9 4 70		
	TD20274	6 10 4.5 70		
	TD20276	7 10 70		
	TD20277	7 11 5.5 100		
	TD20278	8 70		
	TD20279	8 13 6 100		
	TD20282	10 70		
	TD20283	10 16 8 100		

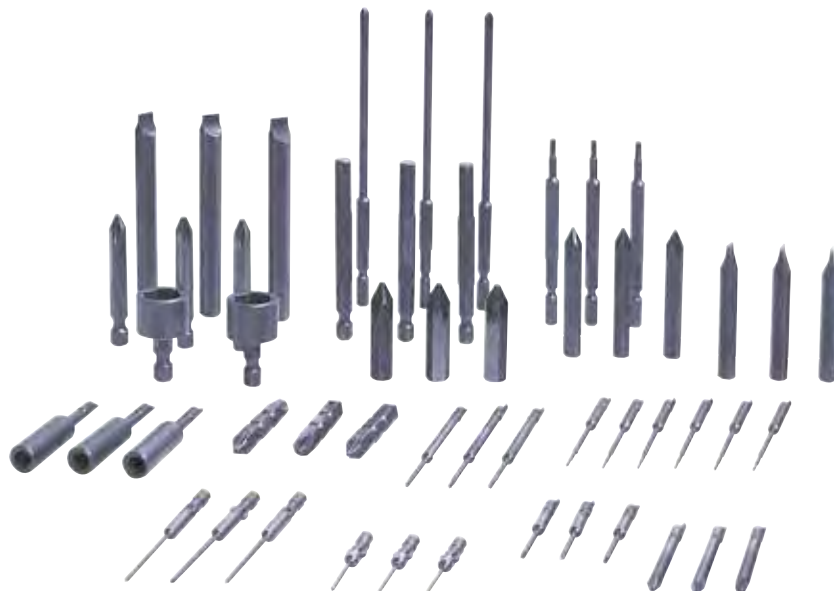

■ For DLV7500, 8500, 7100, 7200, 8100, 8200,
02, 12, 16, A(DLV30A/45A/70A) series

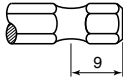

OD 6.35 mm Hex. Shank

Unit: mm

Model	Part No.	Size		Dimensions		
		No. x	d x L			
Phillips NK35	TD20306	1	4	75	 	
	TD20307		100			
	TD20308		50			
	TD20309		75			
	TD20310		100			
	TD20311		120			
	TD20312	150				
	TD20313	200				
	TD20319	2	7	50		
	TD20320		75			
	TD20321		100			
	TD20322		120			
	TD20323		150			
	TD20324		200			
	TD20327	3	50	75		
	TD20328		100			
TD20329	120					
TD20330	150					
TD20331	200					
TD20332	200					
Model	Part No.	No. x	d x L	Dimensions		
Phillips NK36	TD20335	0	3.8	50		
	TD20336	1				
	TD20337	2				
	TD20338	4.5				
Model	Part No.	No. x	L	Dimensions		
Phillips NK15	TD20354	1	1	50		
	TD20355			75		
	TD20356			100		
	TD20357			120		
	TD20358	150				
	TD20359	200				
	TD20362	2	2	50		
	TD20363			75		
	TD20364			100		
	TD20366			150		
	TD20367	200				
	TD20371	3	3	75		
	TD20372			100		
	TD20374			150		
TD20375	200					
Model	Part No.	W x T x	L	Dimensions		
Plain Slot NK35M	TD20378	7	0.9	50		
	TD20379			75		
	TD20380			100		
Model	Part No.	H x d x	L	Dimensions		
Hexagon Head NK35X	TD20382	3	70	1.27	 	
	TD20385			1.5		
	TD20388			2		
	Part No.	H x L				
	TD20391	2.5	70			
	TD20394	3				
	TD20397	4				
	TD20400	5				
TD20404	6					
Model	Part No.	H x D x	d x L	Dimensions		
Hex Socket NK35BN	TD20442	10	16	8		
	TD20443					75
	TD20457	13	19	10		75
	TD20458					100

If Bits other than the above are required,
please contact Nitto Kohki or our distributors.

Vacuum Pickups and Sleeves

Screwdriver series		Vacuum Pickup			Sleeve (Standard accessory)	
		Type	Model	Part No.	Model	
DLV7000/DLV8000/DLV3300		Type A	DLP6500	TD00343	DLS2124/DLS2127/DLS2130	
DLV7400A/DLV5700/DLV5800			DLP5300	TD04342	DLS2120/DLS2124	
DLV7313			DLP7100	TD00345	DLS2122/DLS2124/DLS2127	
DLV7323/DLV7333		Type B	DLP7200	TD00346	DLS2123/DLS2124/DLS2127	
			DLP7300	TD00347	DLS2135	
DLV7100/DLV7200/DLV8100/DLV8200		Type C	DLP7000	TD00344	DLS3223/DLS3225	
DLV7104/DLV8104/DLV8204			DLP7400	TD07285-0	DLS3223/DLS3225	
delvo Brushless Type A series 30A	For HEX. 5 mm (M3, M4)		DLP7400 for High Torque	TD07286-0	DLS4220/DLS4221	
delvo Brushless Type S series 30S						
delvo Brushless Type A series 45A/75A	For HEX. 6.35 mm (M5, M6)	Type D	DLP6600/DLP6610	TD08748/TD08751	DLS2124/DLS2127/DLS2134	
delvo Brushless Type S series 45S/75S	For Ø4 mm For 6.35 mm (1/4")		DLP6640/DLP6650	TD08804/TD08805	DLS4225/DLS4227	
delvo Brushless Type C series						

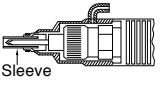
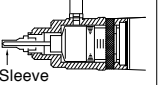
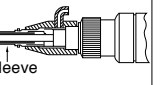
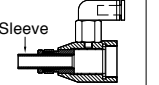
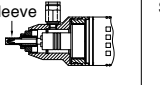
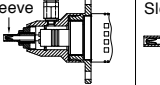
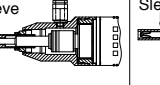
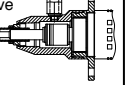
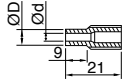
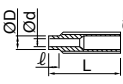
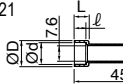
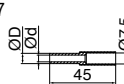
Type	Type A	Type B	Type C	Type D				
Vacuum Pickup								
Sleeve	DLS2000 series (plastic) 		DLS3000 series (metal) 		DLS4000 series (metal) DLS4220/4221 		DLS4225/4227 	

DLS2000 series

Model	Part No.	Sleeve		øD		Bit (No. × d × L) (+)
		mm	inch	mm	inch	
DLS2120	TD00348	2	0.08	3.5	0.14	No. 0 × 1.8 × 44
DLS2121	TD00349	2.2	0.09			
DLS2122	TD00350	2.5	0.1			
DLS2123	TD00351	2.7	0.11			
DLS2124	TD00352	3.1	0.12	4.5	0.18	No. 0 × 2.5 × 44
DLS2125	TD00353	3.3	0.13			
DLS2126	TD00354	3.5	0.14			
DLS2127	TD00355	3.7	0.15			
DLS2128	TD00356	4	0.16	5.5	0.22	No. 1 × 3 × 44
DLS2129	TD00357	4.2	0.17			
DLS2130	TD00358	4.5	0.18			
DLS2131	TD00359	4.7	0.19			6.5
DLS2132	TD00360	5.1	0.2			
DLS2133	TD00361	5.3	0.21			
DLS2134	TD00362	5.6	0.22			
DLS2135	TD00363	6.1	0.24	7	0.28	

DLS3000 series

Model	Part No.	Sleeve		øD		ø		L		Bit (No. × d × L) (+)
		mm	inch	mm	inch	mm	inch	mm	inch	
DLS3222	TD00364	5.6	0.22	7	0.28	5	0.2	34	1.34	No. 1 × 5 × 70
DLS3223	TD05024	6.1	0.24	9	0.35					
DLS3224	TD00365	6.4	0.25							
DLS3225	TD00366	7.1	0.28	7	0.28	18	0.71	65	2.56	No. 2 × 6 × 70
DLS3226	TD00367	4.6	0.18							
DLS3227	TD00368	5.1	0.2							
DLS3228	TD00369	5.6	0.22							
DLS3229	TD00370	6.1	0.24	9	0.35					
DLS3230	TD00371	6.4	0.25							
DLS3231	TD00372	7.1	0.28							

DLS4000 series

Model	Part No.	Sleeve		øD		ø		L		Bit (No. × d × L) (+)
		mm	inch	mm	inch	mm	inch	mm	inch	
DLS4220	TD08001	9.1	0.36	11	0.43	5	0.2	6	0.24	No. 2 × 7 × 75
DLS4221	TD08002	10.6	0.42	12.5	0.49	5.5	0.22	7	0.28	
DLS4225	TD09344	4.6	0.18	7	0.28					No. 1 × 4 × 75
DLS4227	TD09345	5.6	0.22							

Accessories

Tool Balancer



Easy to adjust tension by using handle.

Model	TW-06R	TW-1R	RW-3	RW-5
Capacity (g [lbs])	200 - 600 [0.44 - 1.32]	500 - 1500 [1.1 - 3.31]	1000 - 3000 [2.2 - 6.61]	2500 - 5000 [5.51 - 11.02]
Stroke (m [inch])	1.5 [59"]		2 [78.7"]	
Mass (g [lbs])	300 [0.66]		700 [1.54]	900 [1.98]

Vacuum Pump DLP2500 series



Electric Screwdrivers can be used with Vacuum Pump and Vacuum Pickup. The sleeve of Vacuum Pickup sucks the screw and holds it on the bit, enabling the operator to pick it up with the tool itself, thus improving operational efficiency and operator's productivity.

Model	DLP2530	DLP2570
Features	Standard	With CE mark
Voltage	100 V AC, 50/60 Hz	230 V AC, 50/60 Hz
Power Consumption (W)	30(50 Hz), 26(60 Hz)	
Achievable Vacuum (kPa)	-21.3	
Flow Rate (at Outlet) (L/min)	24(50 Hz), 26(60 Hz)	
Screw Size (mm)	4 or less	
Mass (g [lbs])	3800 [8.38]	

Pistol Grip DLW2300/2300ESD

(for DLV7100, 7200, 8100, 8200, 7500, 8500, 30/45/70-IKE and A(DLV30A/45A/70A) series Electric Screwdrivers)



Easy-to-attach grip suitable for horizontal operation.

Shaker Box Made of Anti-electrostatic Resin

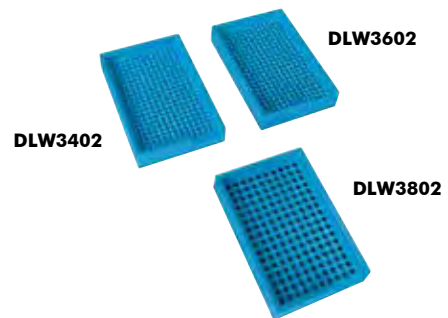

The screws will fall into the heads-up position for easier vacuum or magnetic pickup.

The anti-electrostatic resin greatly reduces static build-up and dust attached to the shaker box.

Model	DLW3402	DLW3602	DLW3802
Part No.	TD04110	TD04111	TD04112
Hole Pitch (mm [inch])	6 [0.24"]		8 [0.31"]
Hole Depth (mm [inch])	13.5 [0.53"]		12.5 [0.49"]
No. of Holes	273	273	160
Screw Size (mm)	1.7 - 2	2 - 2.6	3 - 4

Torque Adjustment Ring Cover



Fits over torque adjustment cover to minimize tampering or accidental turning once the torque is set.

Model	Part No.	Applicable Screwdriver
DLW5200	TD00331	DLV7100, 7200, 8100 and 8200 series
DLW5201*1	TD05639	DLV7100, 7200, 8100 series and DLV30A
DLW5202	TD08486	DLV45S/70S and DLV45A/70A
DLW5203	TD09222	DLV30S and DLV30A
DLW5300	TD00332	DLV7301, 7000, 8000 series (for 4 mm bit)
DLW5400	TD01883	DLV7301 series (for 6.35 mm bit)
DLW5500	TD00333	DLV7303 series (for 4 mm & 6.35 mm bit)
DLW5600	TD00334	DLV7500, 8500 series
DLW5700	TD02875	DLV5700, 5800, 7400A series
-	TV07315	DLV02/12/16SL-BKE series
-	TV06787	DLV02/12/16SL-CKE series

*1: As this is a clear plastic cover, torque scale can be seen even after mounted on the screwdriver.

Flanged Coupling DLW9011

(for DLV7100, 7200, 8100, and 8200 series Electric Screwdrivers)

*Can not be mounted on SPC type



Provides a flange which enables the operator to apply axial pressure through the heel of the hand.

Accessories

Torque Reaction Arm

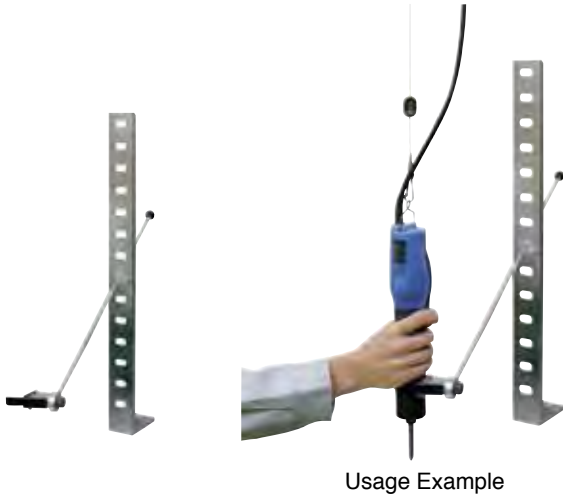

For enhanced productivity and prevention of operator's repetitive motion injury, a torque reaction arm should be used all together.

Part No.	Description	Applicable Screwdriver
TD06180	Torque Reaction Arm	A series(DLV30A/45A/70A) S series(DLV30S/45S/70S)

Optional Cord

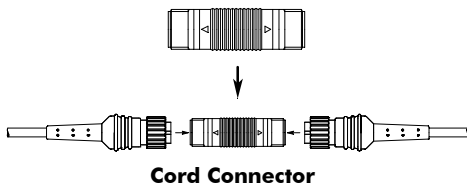
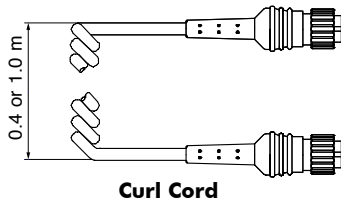

Please inquire of the distributor for the price and minimum quantity on each optional cord.

Part No.	Optional Cord	Applied Models	Length (m)
TD02826	5P to 6P Exchange Cord*1	DLV7300 series	0.1
TD02548	Extension Cord For 5P		3.0
TD03159	Extension Cord For 6P		2.0
TD01882	Curl Cord	DLV7500/8500 series	0.4
TD02820	Curl Cord		1.0
TD02438	Cord Connector DLW9100		

*1: "5P to 6P Exchange Cord" is used to connect "5-prong Screwdriver" to "6-prong Controller".

SAFETY GUIDE

Be sure to read and understand the following safety notations and all safety precautions.

 **WARNING:** Indicates a potentially hazardous situation which, if failure to comply with the instructions given, could result in serious injury or death.

 **CAUTION:** Indicates a potentially hazardous situation which, if failure to comply with the instructions given, could result in injury or material damage.

Safety Precautions

- Be sure to follow the safety precautions to keep accidents such as fires, electroshock, and injuries from occurring.
- Before using your tool, please read this manual carefully so that you may use it properly to get the most out of it.
- Keep the manual handy – so you can use it whenever necessary.

WARNING

- Keep work area clean. Cluttered work areas and benches invite accidents and injuries.
- Consider proper working environments for each tool carefully. Do not expose electric tools to extreme amounts of moisture or direct contact with water or rain. Keep area well lit at all times to prevent hidden dangers and never operate the equipment near flammable liquids or in gaseous or explosive atmospheres.
- Prevent operators from electric shock. When using electric tools, prevent body contact with grounded surfaces (e.g. pipes and outer frames of radiators, microwave ovens, and refrigerators, etc.).
- Keep all electric tools and power cords away from children and all unauthorized personnel. Also all visitors should be kept away from work area.
- Properly store tools and accessories while not in use. They should be kept in a dry, locked-up location out of reach of children or unauthorized personnel.
- Do not force tool. It will do the job better and more safely at the rate for which it was intended.
- Use the right electric power tool that can complete the job within its specifications. Do not attempt to adapt improper attachments or accessories to complete a job. Do not use the tool for other than what they were designed for.
- Dress properly. Do not wear loose clothing and/or accessories. (gloves, necklace etc.) They can be caught in moving parts. Non-skid footwear is recommended in outdoor operation. Wear protecting hair covering to contain long hair.
- Always wear safety glasses during operation. Wear respiratory protection when working in an environment where dust particles are generated during operation.
- Do not abuse cord. Never carry tool by cord or yank it to disconnect from receptacle. Keep cord from heat, oil, and sharp edges.
- Use clamps or a vise to secure the work piece tightly and eliminate vibration. Never hold the work piece with your hands, keep both hands on the electric tool for increased productivity.
- Do not overreach. Keep proper footing and balance at all times.
- Maintain tools with care. For safe and efficient work, use the proper bit and check it regularly. Do not use the bit with a worn out or deformed tip. When oiling and replacing parts, follow the instructions given by the instruction manual. Inspect tool cords periodically and if damaged, have them replaced by an authorized service facility. Keep handles dry, clean, and free from oil and grease.
- Disconnect a tool or a controller when not in use, when repairing, or when changing accessories and bits, etc.
- Remove adjusting keys and wrenches. Form habit of checking to see that keys and adjusting wrenches are removed from tools before turning it on.
- Always avoid an unexpected start by having all power switches in the off position prior to attaching to a power supply. Never carry tools with your finger on the on/off switch when the power is attached. Never plug the cord into a receptacle while your finger is on the on/off switch.
- When the tool is used outdoors, use an electric extension cord or cable suitable for outdoor use.
- Stay alert. Watch what you are doing. When using electric tools, take good care of tool handling, working manner, and surrounding conditions. Use common sense. Do not operate tool when you are tired.
- Check damaged parts. Before further use of the tool, an accessory or other part that is damaged should be carefully checked to determine that it will operate properly and perform its intended functions. Check for alignment of moving parts, binding of moving parts, breakage of parts, mounting, and any other conditions that may affect its operation. When repairing or replacing parts, follow the directions of the instruction manual. The part that is damaged should be properly repaired or replaced by an authorized service facility unless otherwise indicated elsewhere in this operation manual. Have defective switches replaced by an authorized service facility. Do not use the tool if the switch cannot be turned on and off.
- Use only recommended accessories and attachments as per tool operator manual and “delvo” general catalog. Use of improper accessories and attachments may result in an accident or serious injury.
- Any repairs on the tool should be performed only by an authorized service facility. Do not modify the tool that is complying with the safety standard. If the repairman who has poor knowledge and skill repairs the tool, the tool may not give a good performance and result in an increased risk of injury to the user.
- The power source must be limited to the individual tools specifications as stated on the nameplate or instruction manual. If used at a higher or lower voltage than indicated, it may cause failure and result in an increased risk of injury to the user.
- Before work operation carefully check if there are underground installations such as conduit, water pipe, and gas pipe, etc. If a tool should touch them, it might cause electric shock, electric leak, or gas leak.
- Hold the tool body firmly so as not to be swung by it when using. If not, this may cause injury.
- Do not bring hand or face close to moving parts such as bit etc. when using. This may cause injury.
- When you have dropped the tool by mistake, carefully check the tool if there is breakage, cracks or deformation. This may cause injury.

CAUTION

- Install bits or accessories securely in accordance with the operation manual. Insufficient installation may cause injury.
- Whenever setting the torque, unplug the cable of the tools. Adjusting the torque setting during rotation may cause injury.
- When operating a tool at high places, check that there is no person under the places. Do not stumble over the cord nor drop the material or tool body. This may cause injury.
- Never leave a tool running unattended on the working bench or floor. Always turn the power switch or lever to the off position and disconnect from the power source when not in use.
- Do not overload to the extent that the motor locks or the clutch malfunctions. This may cause smoke, fire, failure or injury.
- If the tool is overheating or functioning abnormally, stop using the screwdriver immediately and inspect it to see whether any repairs are necessary. Otherwise this may cause failure or injury.
- The electric screwdriver may overheat depending on the type of screw, type of screw-tightened material, or frequency of use. To avoid overheating, stop operating the screwdriver for a time or use several drivers in alteration. Overheating may reduce the life of the product or cause failure or injury.
- The fastening torque may vary depending on how the product is operated or held, the type of screw, and the fastening conditions. Use a torque wrench or similar tool to check that the fastening torque is appropriate.

delvo

Electric Screwdrivers



ISO 9001
JQA-2025
ISO 14001
JQA-EM4057
H.Q./R&D Lab

LARWIND

The logo for delvo is registered trademark or a trademark of Nitto Kohki Co., Ltd. in Japan, the United States and/or certain other countries.

DISTRIBUITO BY

LARWIND

Larwind Neumática, S.A.

Polígono Arriagane Parcela 14 Alta (Boroa)
48340 - Amorebieta - Etxano (Bizkaia) SPAIN
Tel. +34 94 631 20 03 Fax +34 94 631 35 12
larwind@larwind.es www.larwind.com